

# FLIGHT MANUAL

## USAF SERIES T-41C/D AIRCRAFT

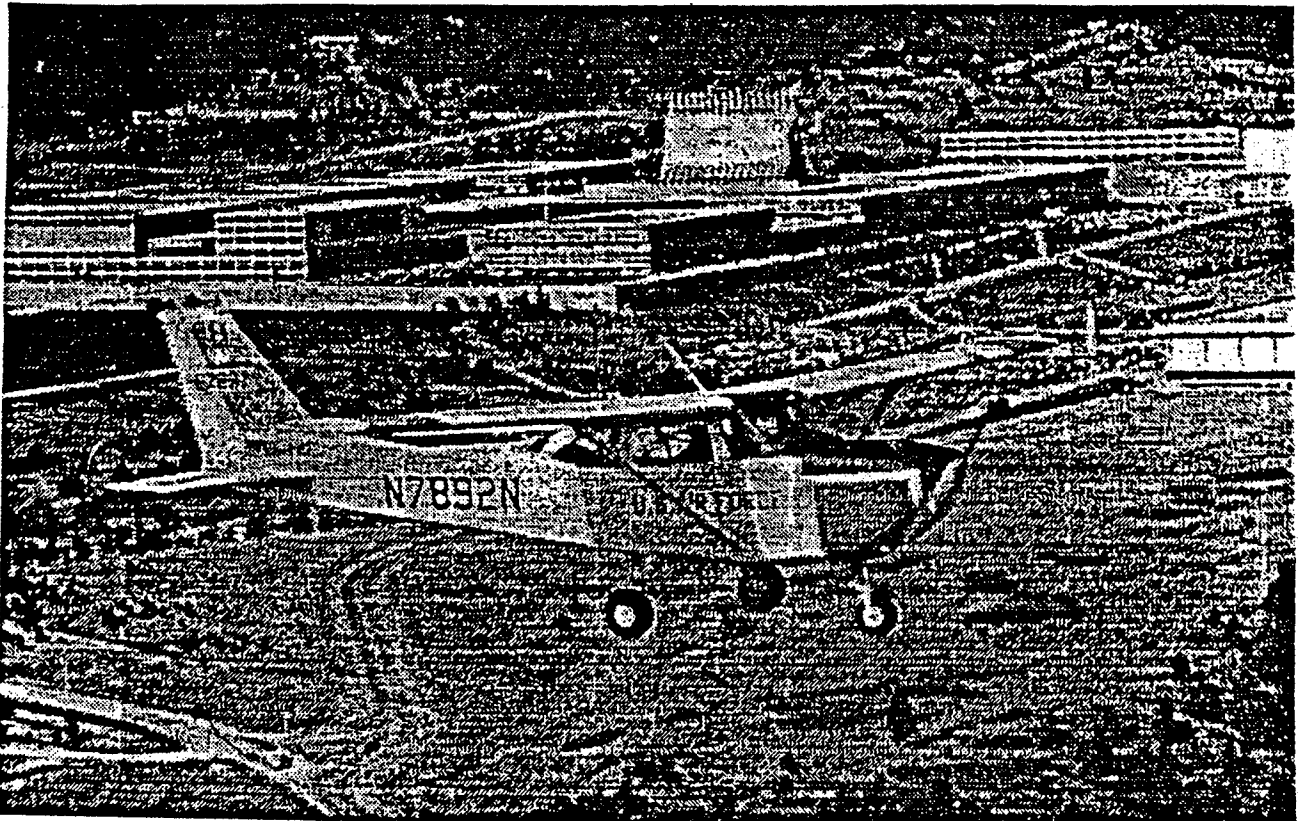

F34601-90-D-0311

**DISTRIBUTION STATEMENT** - Distribution authorized to the Department of Defense and U.S. DoD contractors only, Administrative and Operational Use, 15 September 1990. Other requests shall be referred to OC-ALC/TISDT, Tinker AFB, OK 73145-5990.

**WARNING** - This document contains technical data whose export is restricted by the Arms Export Control Act (Title 22, U.S.C., Sec. 2751 et seq.) or the Export Administration Act of 1979, as amended (Title 50, U.S.C., App. 2401 et seq.). Violations of these export laws are subject to severe criminal penalties.

**HANDLING AND DESTRUCTION NOTICE** - Handle in compliance with the distribution statement and destroy by any method that will prevent disclosure of the contents or reconstruction of the document.

**COMMANDERS ARE RESPONSIBLE FOR BRINGING THIS PUBLICATION  
TO THE ATTENTION OF ALL AFFECTED PERSONNEL.**

PUBLISHED UNDER AUTHORITY OF THE SECRETARY OF THE AIR FORCE

AIR FORCE 13 May 91 / 865

**B**

**15 SEPTEMBER 1990**

**CHANGE 1**

**15 APRIL 199**

# OPERATIONAL SUPPLEMENT

## USAF MODEL T-41C/D AIRCRAFT FLIGHT MANUAL

F34601-90-D-0311

THIS PUBLICATION SUPPLEMENTS T.O. 1T-41C-1, DATED 15 SEPTEMBER 1990.

**DISTRIBUTION STATEMENT** - Distribution authorized to the Department of Defense and U.S. DoD contractors only, Administrative or Operational Use, 15 September 1990. Other requests shall be referred to OC-ALC/TISDT, Tinker AFB, OK 73145-5990.

**WARNING** - This document contains technical data whose export is restricted by the Arms Export Control Act (Title 22, U.S.C., Sec. 2751 et seq.) or the Export Administration Act of 1979, as amended (Title 50, U.S.C., App. 2401 et seq.). Violations of these export laws are subject to severe criminal penalties.

**HANDLING AND DESTRUCTION NOTICE** - Handle in compliance with the distribution statement and destroy by any method that will prevent disclosure of the contents or reconstruction of the document.

**COMMANDERS ARE RESPONSIBLE FOR BRINGING THIS SUPPLEMENT TO THE ATTENTION OF ALL AFFECTED AIR FORCE PERSONNEL.**

PUBLISHED UNDER AUTHORITY OF THE SECRETARY OF THE AIR FORCE

21 MARCH 1991

### NOTICE TO AIRCREWS

Write the number of this supplement alongside the changed portion of the flight manual.

1. PURPOSE

To provide-aircrews with guidance on hydroplaning.

2. GENERAL

Due to a Class C Flight Mishap Report and the resulting Oklahoma City ALC Material Safety Task Group recommendations the following hydroplaning guidance is added.

OPERATIONAL SUPPLEMENT

3. INSTRUCTIONS

- A. Add this Data to page 7-1, right column after first Warning and before the topic, "Turbulence and Thunderstorms." Number accordingly.

**HYDROPLANING**

Hydroplaning occurs when the coefficient of friction between the tires and runway is reduced by some form of fluid. The major factors in determining when an airplane will hydroplane are ground speed, tire pressure and surface water depth. To a lesser degree the runway surface texture, type of tire and tread depth influence the tire hydroplaning speed. Hydroplaning falls into three classifications: Dynamic, Viscous, and Reverted Rubber.

**DYNAMIC HYDROPLANING**

Dynamic hydroplaning occurs gradually as a wedge of water builds up pressure between the tires and pavement. Under conditions of total dynamic hydroplaning, the tires lose contact with the runway. A nonrotating tire during landing may not spin up at touchdown or the rolling (unbraked) tire on the runway may slow in rotation and actually come to a stop. Under these conditions, the coefficient of friction is reduced to zero making wheel braking, tire cornering, and steering totally ineffective. Once total dynamic hydroplaning begins, it may continue after the tire speed decreases.

**VISCOUS HYDROPLANING**

Viscous hydroplaning occurs at lower speeds than dynamic hydroplaning on runways surfaces with smooth surface texture or made smooth by rubber deposits or runway marking paint. This type of hydroplaning may perpetuate itself at low speeds if the thin water layer is not broken by an irregular surface. Dew can produce viscous hydroplaning conditions on very smooth pavement resulting in a viscous film that acts as a lubricant.

**REVERTED RUBBER HYDROPLANING**

Reverted rubber hydroplaning is caused by a skid which boils water on the runway, causing heated rubber to revert to its natural latex state sealing tire grooves which prevents water dispersal. This type of hydroplaning results in near zero braking coefficients and has been known to continue almost to the point of zero ground speed.

**RUNWAY SURFACE FACTORS**

The risk of hydroplaning decreases if the runway surface is crowned, grooved and textured. Rubber and contaminants embedded in the runway touchdown zone in combination with moisture increase the probability of viscous hydroplaning. When slush is present on a crowned runway, drainage is reduced increasing the likelihood of dynamic hydroplaning. Runway surface texture has little effect on the alleviation of reverted rubber hydroplaning.

**WEATHER AND TIRE CONDITIONS**

On dry runway surfaces the coefficient of friction is unaffected by tire wear. High ambient temperatures combined with smooth asphalt or newly resealed/resurfaced runways may produce a phenomenon similar to hydroplaning. A locked wheel may aggravate or initiate this condition.

Smooth tires may hydroplane with 0.1 inch of water. Ribbed tires will release hydrodynamic pressure and will not hydroplane until water depth is 0.2 to 0.3 inch. Higher tire pressures will reduce the possibility of hydroplaning. The minimum total hydroplaning speed in knots, for tires operating in fluid deeper than their tread depth, is approximately equal to nine times the square root of the tire inflation pressure.

Without measured runway water depths, on runways with standing water, use the following information to determine the possibility of hydroplaning.

# Technical Order/Equipment Configuration Status Record

ECP TCTO NO.	TITLE	INCORP. DATE

- a. Rain reported as LIGHT - Dynamic hydroplaning unlikely; viscous and reverted hydroplaning are possible.
- b. Rain reported as MODERATE - All types of hydroplaning are possible. Smooth tires will likely hydroplane.
- c. Rain reported as HEAVY - Hydroplaning will occur.

Hydroplaning reduces the effectiveness of nose wheel steering and consequently the ability of the pilot to cope with crosswinds.

THE END

# Flight Manual, Safety Supplement, and Operational Supplement Status

This page is published with each Safety and Operational Supplement, and each Flight Manual Change or revision. It provides a comprehensive listing of the current Flight Manuals, Flight Crew Checklist, Safety Supplements, and Operational Supplements. If you are missing any publications listed on this page, see your Publications Distribution Officer and get your copy. Changes in preparation are shown in parentheses ( ).

<i>FLIGHT MANUAL</i>	<i>DATE</i>	<i>CHANGE</i>
T.O. 1T-41C-1	1 Aug 90	1 - 15 Apr 91

<i>FLIGHT CREW CHECKLIST</i>	<i>DATE</i>	<i>CHANGE</i>
T.O. 1T-41C-1CL-1	1 Aug 90	1 - 15 Apr 91

# Flight Manual, Safety Supplement, and Operational Supplement Status

## CURRENT SUPPLEMENTS

<i>Number</i>	<i>Date</i>	<i>Short Title</i>	<i>Flight Manual Pages Affected</i>
<i>T.O. 1T-41C- 15-2</i>	<i>21 MAR 91</i>	<i>HYDROPLANING</i>	<i>7-1</i>

## REPLACED/RESCINDED SUPPLEMENTS

<i>Number</i>	<i>Date</i>	<i>Disposition</i>
---------------	-------------	--------------------

# TABLE OF CONTENTS

<i>SECTION</i>	<i>TITLE</i>	<i>PAGE</i>
I	Description and Operation .....	1-1
II	Normal Procedures .....	2-1
III	Emergency Procedures .....	3-1
IV	Crew Duties (Not Applicable) .....	4-1
V	Operating Limitations .....	5-1
VI	Flight Characteristics .....	6-1
VII	All Weather Operation .....	7-1
GLOSSARY .....		G-1
APPENDIX - Performance Data .....		A-1
Alphabetical INDEX .....		INDEX-1



# LIST OF ILLUSTRATIONS

<i>Figure</i>	<i>Title</i>	<i>Page</i>
1	The T-41C Aircraft .....	ix
1-1	Principal Dimensions .....	1-2
1-2	Left Lower Switch Panel .....	1-3
1-3	Right Lower Switch Panel .....	1-3
1-4	Cockpit Forward View .....	1-4
1-5	Oil System Schematic .....	1-8
1-6	Fuel System Schematic .....	1-9
1-7	Fuel Quantity Data (U.S. Gallons) .....	1-11
1-8	Electrical System Schematic .....	1-12
1-9	VHF Radio .....	1-18
1-10	VOR Receiver .....	1-18
1-11	Transponder .....	1-19
2-1	Exterior Inspection .....	2-3
2-2	Wind Direction .....	2-7
2-3	Traffic Pattern .....	2-11
3-1	Maximum Glide .....	3-4
3-2	Typical Forced Landing Pattern .....	3-7
5-1	Airspeed Limitations Gauge .....	5-1
5-2	Oil Temperature Gauge .....	5-2
5-3	Oil Pressure Gauge .....	5-2
5-4	Tachometer .....	5-2
5-5	Fuel Flow Indicator .....	5-3
5-6	Fuel Quantity Indicator .....	5-3
5-7	Suction Gauge .....	5-3
6-1	Stalling Speeds (2200 Pounds Gross Weight) .....	6-1
6-2	Stalling Speeds (2500 Pounds Gross Weight) .....	6-1
A1-1	Airspeed Conversion Chart .....	A-2
A1-2	Airspeed Correction Table .....	A-3
A1-3	T-41C Airspeed correction Chart .....	A-3
A1-4	Weight and Balance Chart .....	A-4
A1-5	Center of Gravity Moment Envelope .....	A-5
A1-6	Loading Graph .....	A-5
A1-7	Takeoff and Landing Crosswind Chart .....	A-6
A1-8	Take-Off Data .....	A-7
A1-9	Maximum Rate-of-Climb Data .....	A-7
A1-10	Optimum Cruise Performance .....	A-7
A1-11	Cruise & Range Performance Data .....	A-8
A1-12	Landing Distance Data .....	A-8
A1-13	Take-Off Data, T-41D Model .....	A-9
A1-14	Maximum Rate-of-Climb Data, T-41D Model .....	A-9
A1-15	Cruise Performance (2500 feet) .....	A-10
A1-16	Cruise Performance (5000 feet) .....	A-11
A1-17	Cruise Performance (7500 feet) .....	A-12
A1-18	Cruise Performance (10,000 feet) .....	A-13

# Coding and Serialization

**D**

Indicates information that applies to "D" modified airplanes.

## AIRCRAFT CODING "D" MODEL

69-7755

69-7756

All other airplanes are standard "C" models.

# IMPORTANT! Read these pages carefully

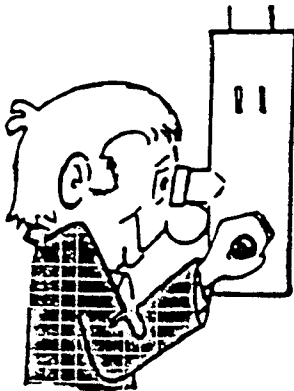

## SCOPE.

The information in the manual provides you with a general knowledge of the airplane, its characteristics, and specific normal and emergency operating procedures. Your flying experience is recognized; therefore, basic flight principles are avoided. This manual provides the best possible operating instruction under most circumstances, but are a poor substitute for sound judgement. Multiple emergencies, adverse weather, terrain, or extenuating circumstances may require modification of the procedure(s) presented in this manual.



## FLIGHT MANUAL BINDERS.

Looseleaf binders and sectionalized tabs are available for use with your manual. They are obtained through local purchase procedures and are listed in the Federal Supply Schedule (FSC Group 75, Office Supplies, Part 1). Check with your supply personnel for assistance in procuring these items. Due to the size of section I it is suggested that dividers be used at the beginning of each system description.

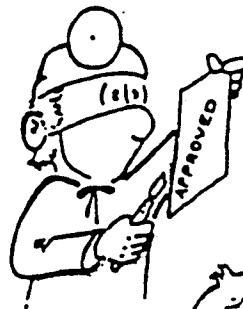

## PERMISSIBLE OPERATIONS.

The Flight Manual takes a "positive approach" and normally states only what you can do. Usually operations or configurations which exceed the limitations as specified in this manual are prohibited, except in actual emergencies, unless authorized by HQ USAF ACADEMY/CWO.



## HOW TO BE ASSURED OF HAVING LATEST DATA . . .

You must remain constantly aware of the latest manual, checklists and status of supplements. T.O. 0-1-1-3 (supplemented monthly) and the latest flight manual or supplement status page provide a listing of the current flight manuals, checklists and supplements.



## ARRANGEMENT.

This manual is divided into seven interdependent sections to simplify reading it straight through or using it as a reference manual. For convenience, section I has been divided into 20 subsections, describing major systems or groups of related systems. You must be familiar with the system operating instructions in section I, the limitations in section V and the flight characteristics in section VI, to perform the procedures sections II, III, and IV. In adverse weather conditions, the procedures in sections II and III shall be modified as shown in section VIII.

## CHECKLISTS.



The Flight Manual contains the amplified checklists. Abbreviated checklists have been issued as separate technical orders. See the latest supplement status page for current applicable checklists. Line items in the Flight Manual and checklists are arranged in the same order. If authorized by an interim Safety or Operational Supplement that affects a checklist, write in the applicable change on the affected checklist page. If a printed supplement contains a replacement checklist page, file the page in front of the existing checklist page, but do not throw out the old page (in case the supplement is cancelled).

## HOW TO GET PERSONAL COPIES.



Each flight crew member is entitled to personal copies of the Flight Manual, Safety Supplements, Operational Supplements, and Checklists. The required quantities should be ordered before you need them to assure their prompt receipt. Check with your Flight Manuals personnel - it is their job to fulfill your Technical Order requests. Basically, you must order the required quantities on the publication Requirements Table (T.O. 0-1-1-3). Technical Orders 00-5-1 and 00-5-2 give detailed information for properly ordering these publications. Make sure a system is established at your base to deliver these publications to the flight crews immediately upon receipt.

## SAFETY AND OPERATIONAL SUPPLEMENTS.

Safety supplements are a rapid means of transmitting information about hazardous conditions or safety problems. These supplements contain operating instructions, or restrictions that affect safety or safety modifications. Operational supplements are a rapid means of transmitting information not involving safety. Supplements are issued by teletype (interim) or as printed (formal) supplements. Interim supplements are either replaced by a formal printed supplement (with a new number) or by a quick change to the manual. Formal supplements are identified by red letters "SS" or by black letters "OS" around the borders of the pages.



All supplements are numbered in sequence. A safety supplement has the letters 'SS' in the number. An operational supplement has the letter 'S' in the number. All current supplements must be complied with. A safety and operational supplement status page is in each printed supplement and each change to this manual (pages i and ii) to show the current status of supplements and checklists. These pages are only current when prepared. To be sure of the latest information check the index, T.O. 0-1-1-3. The title page of this manual and the title block of each supplement show the effect of each change on supplements. File supplements in front of the manual, with the latest on top, regardless of whether it is an operational supplement or safety supplement.

**CHANGE SYMBOL**

The change symbol, as illustrated by the black line in the margin of this paragraph, indicates text changes made to the current revision. Changes to illustrations are indicated with a miniature hand.

**WARNINGS, CAUTIONS, AND NOTES.**

The following definitions apply to "Warnings," "Cautions," and "Notes" found through the manual.

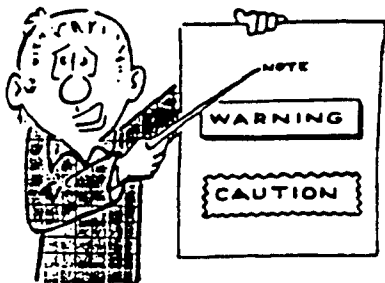

Operating procedures, techniques, etc., which can result in personal injury or loss of life if not carefully followed.



Operating procedures, techniques, etc., which can result in damage to equipment if not carefully followed.

**NOTE**

An operating procedure, technique, etc., which is considered essential to emphasize.

The following definitions apply to the words "shall," "will," "should," and "may":

**SHALL or WILL**

Used to express that the requirements are binding and mandatory.

**SHOULD**

Used to express a non-mandatory desire or preferred method of accomplishment and shall be construed as a non-mandatory provision.

**MAY**

Used to express an acceptable or suggested means of accomplishment and shall be construed as a non-mandatory provision. Not used to express possibility ("might").

**YOUR RESPONSIBILITY — TO LET US KNOW .**

Every effort is made to keep the Flight Manual current. Review conferences with operating personnel and a constant review of accident and flight reports assure inclusion of the latest data in the manual. However, we cannot correct an error unless we know of its existence. Comments, corrections and questions regarding this manual or any phase of the Flight Manual program are welcomed. These should be forwarded through your major command on AF Form 847 to Oklahoma City ALC/TISDTM Tinker AFB, Oklahoma 73145-5990.



# T-41C

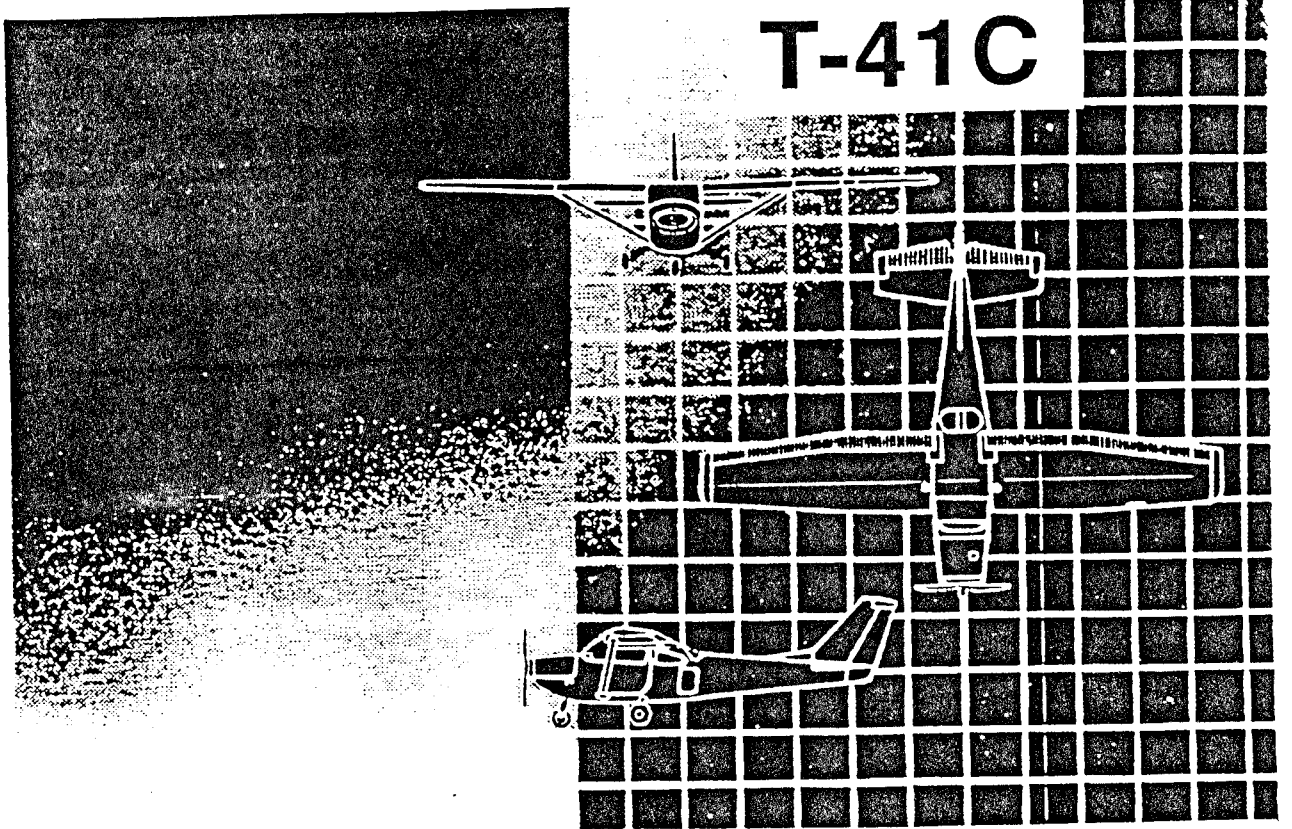

Figure 1. The T-41C Aircraft

**SECTION I**

**DESCRIPTION AND OPERATION**

**Table of Contents**

The Aircraft .....	1-1
Engine .....	1-1
Fuel Injection/Air Induction System .....	1-2
Propeller .....	1-5
Engine Instruments .....	1-6
Oil system .....	1-7
Fuel System .....	1-7
Electrical System .....	1-10
Nosewheel Steering System .....	1-13
Brake System .....	1-13
Wing Flap System .....	1-13
Flight Control System .....	1-14
Stall Warning Horn .....	1-14
Instruments .....	1-14
Communications/Navigation Equipment .....	1-16
Lighting .....	1-17
Cabin Heating and Ventilation System .....	1-19
Cabin Doors .....	1-20
Seat Operation .....	1-20
Seat Belts and Shoulder Harnesses .....	1-20

**THE AIRCRAFT**

The T-41C, designed and manufactured by Cessna Aircraft Company, is an all metal, single-engine, strut-balanced, high wing monoplane. Distinguishable features of the aircraft are its single engine placed forward on the fuselage centerline and fixed tricycle landing gear. The propeller is all metal, fixed pitch, and designed for best climb. Aircraft are generally configured with two forward side-by-side seats with the capability of conversion to four-place seating. On T-41D aircraft, the T-41D has the same characteristics as T-41C. The T-41D has a variable pitch propeller which improves performance.

**Dimensions**

The overall dimensions of the aircraft are as follows: (Figure 1-1)

Wing Span .....	36'2"
Height .....	8' 9 1/2"
Length .....	25'11"
Wheel Base .....	7'2"
Propeller .....	6'6"

**Gross Weight**

This aircraft is FAA-certified in both the normal and utility categories. Maximum gross weights are as follows:

Normal .....	2,500 lbs
Utility .....	2,200 lbs
<b>D</b> Normal .....	2,550 lbs
<b>D</b> Utility .....	2,250 lbs

Refer to Section V, Weight Limitations, for additional information.

**ENGINE**

The aircraft is powered by a horizontally-opposed, fuel-injected, six-cylinder Continental Model IO-360-D engine, rated at 210 bhp at 2,800 RPM. As an internal combustion engine, power to turn the propeller is derived from the ignition of fuel and air in the six cylinders. Spark to ignite the fuel and air is provided by two magnetos and is controlled by the ignition switch. The ratio of fuel and air ignited in the cylinders is determined by atmospheric pressure (see engine-driven fuel pump) and the position of the throttle and mixture knobs in the cockpit.

## Ignition System

Anytime the engine is turning, ignition is supplied by two magnetos. Each magneto supplies power to its associated set of spark plugs. The magnetos are engine-driven and self-contained. They are independent of the aircraft electrical system and of each other. Magneto operation is checked as outlined in Section II, Before Takeoff Check.

## Ignition Switch

The ignition switch, located on the left lower switch panel, controls the ignition system (figure 1-2). The switch is labeled OFF, R, L, BOTH, START, in a clockwise direction. The R and L positions are for checking the magneto system or emergency purposes only. The position of the ignition switch determines which portions of the system are operating.

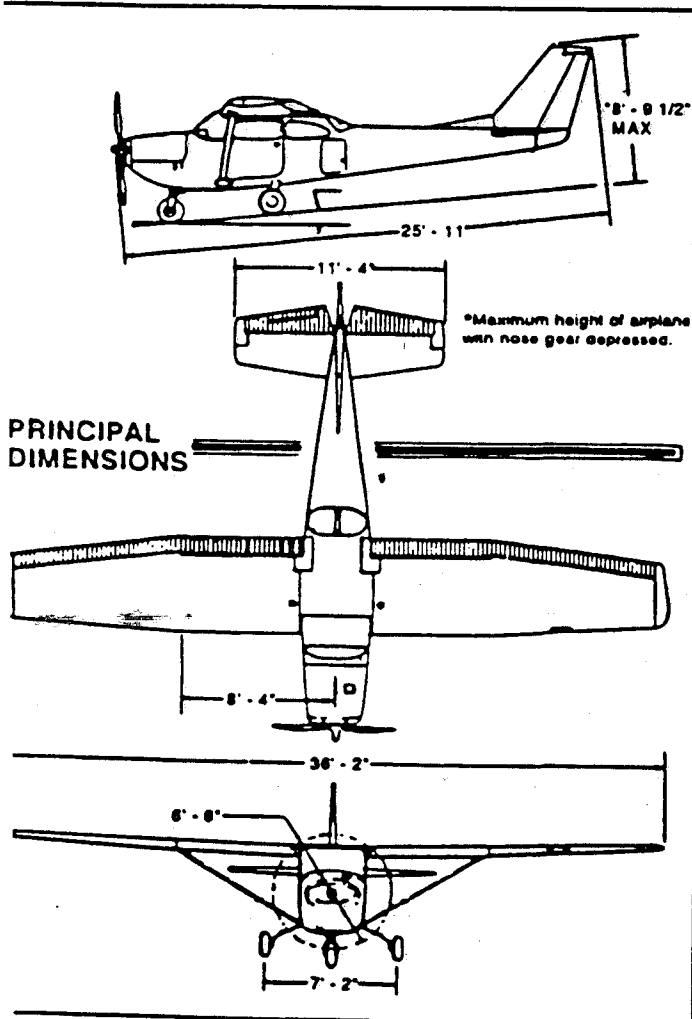

Figure 1-1. Principal Dimensions

## Starting System

Electrical power for energizing the starter may be supplied by the aircraft battery or an external power source. When the ignition switch is turned to the spring-loaded START position (with the master switch ON) the starter solenoid closes allowing voltage to flow to the starter motor, cranking the engine. As the switch is released, it automatically returns to the BOTH position.

### CAUTION

Release the starter as soon as the engine fires. Never engage the starter while the propeller is turning. Do not operate the starter motor more than a total of 30 seconds at one time. If the engine fails to start within 30 seconds of cumulative cranking, allow a 3 minute cooling period before reengaging the starter.

## Mixture Control

The mixture control knob is to the right of the throttle and is identified by a red knob with a silver push button lock in the center. Moving the control knob forward or aft to adjust the mixture is accomplished by rotating the knob clockwise toward full rich or counterclockwise toward full lean. If large or rapid changes are required, depress the lock button on the control knob and position the control forward or aft as required.

## Throttle

Engine power is controlled by the throttle which is identified by its smooth, round white knob. The throttle is operated in the conventional manner - in the forward position the throttle is open, and in the aft position it is closed.

## FUEL INJECTION/AIR INDUCTION SYSTEM

Fuel and air arrive at the cylinders for combustion separately, via the fuel injection system and air induction manifold. Fuel flow is metered by the aneroid in the engine-driven rotary vane fuel pump. The aneroid automatically changes the mixture with altitude changes. The mixture unit also meters fuel based on the position of the mixture control knob.



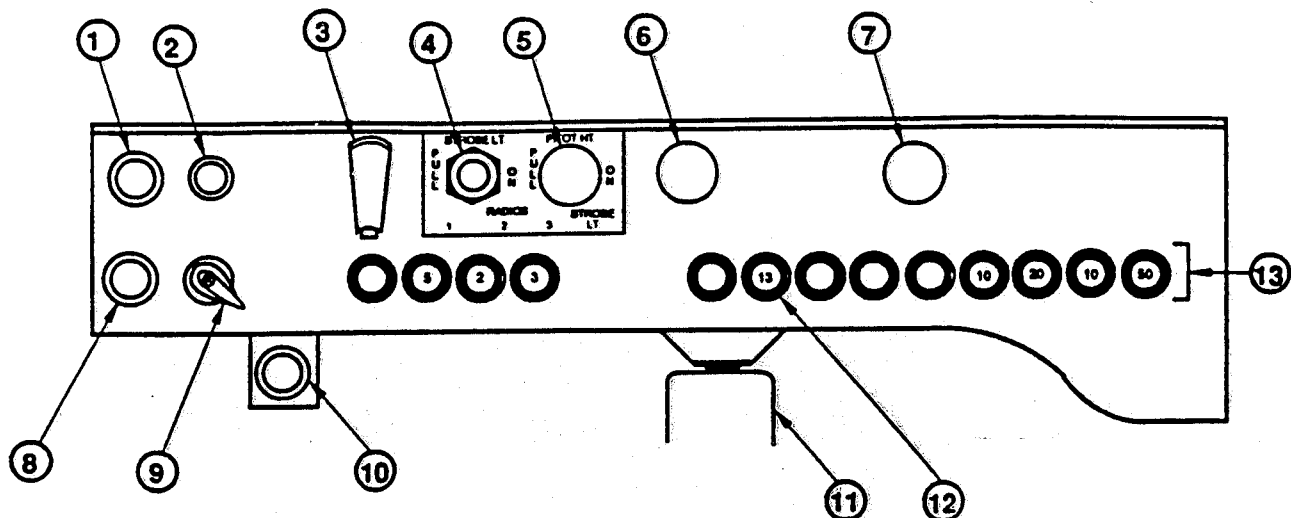

- |                               |                          |
|-------------------------------|--------------------------|
| 1. FUEL STRAINER KNOB         | 8. MANUAL PRIMER KNOB    |
| 2. MASTER SWITCH              | 9. IGNITION SWITCH       |
| 3. AUXILIARY FUEL PUMP SWITCH | 10. FUEL SHUTOFF KNOB    |
| 4. STROBE LIGHT SWITCH        | 11. PARKING BRAKE        |
| 5. PITOT HEAT SWITCH          | 12. FLAP CIRCUIT BREAKER |
| 6. NAVIGATION LIGHT SWITCH    | 13. CIRCUIT BREAKERS     |
| 7. LANDING/TAXI LIGHT SWITCH  |                          |

Figure 1-2. Left Lower Switch Panel

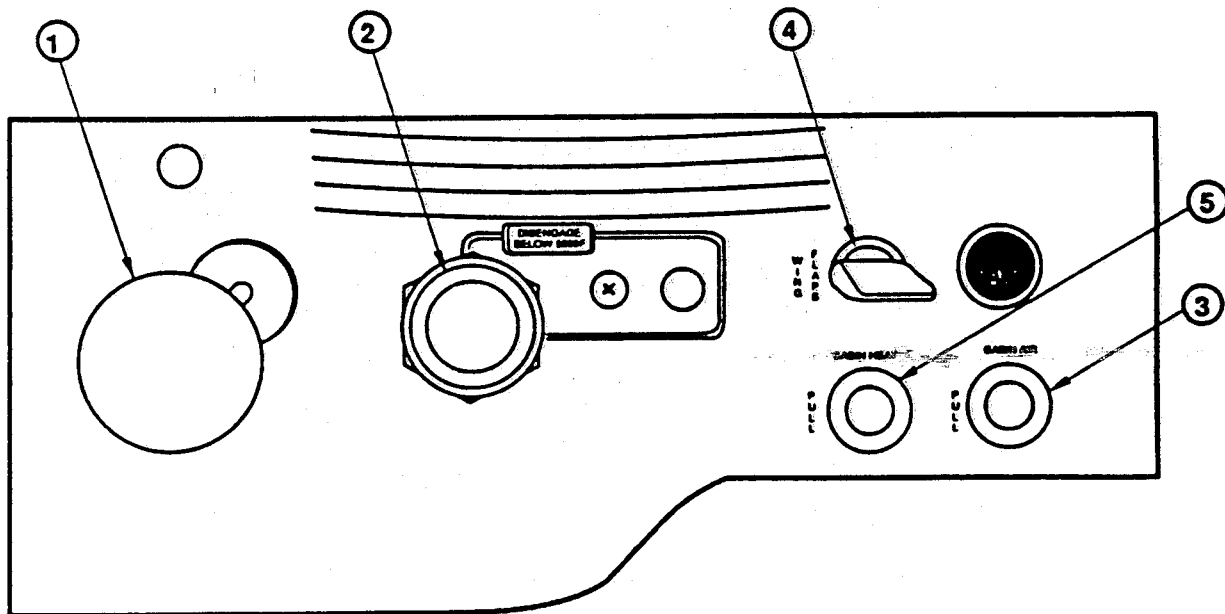

- |                      |                    |
|----------------------|--------------------|
| 1. THROTTLE          | 4. FLAP SWITCH     |
| 2. FUEL MIXTURE KNOB | 5. CABIN HEAT KNOB |
| 3. CABIN AIR KNOB    |                    |

Figure 1-3. Right Lower Switch Panel

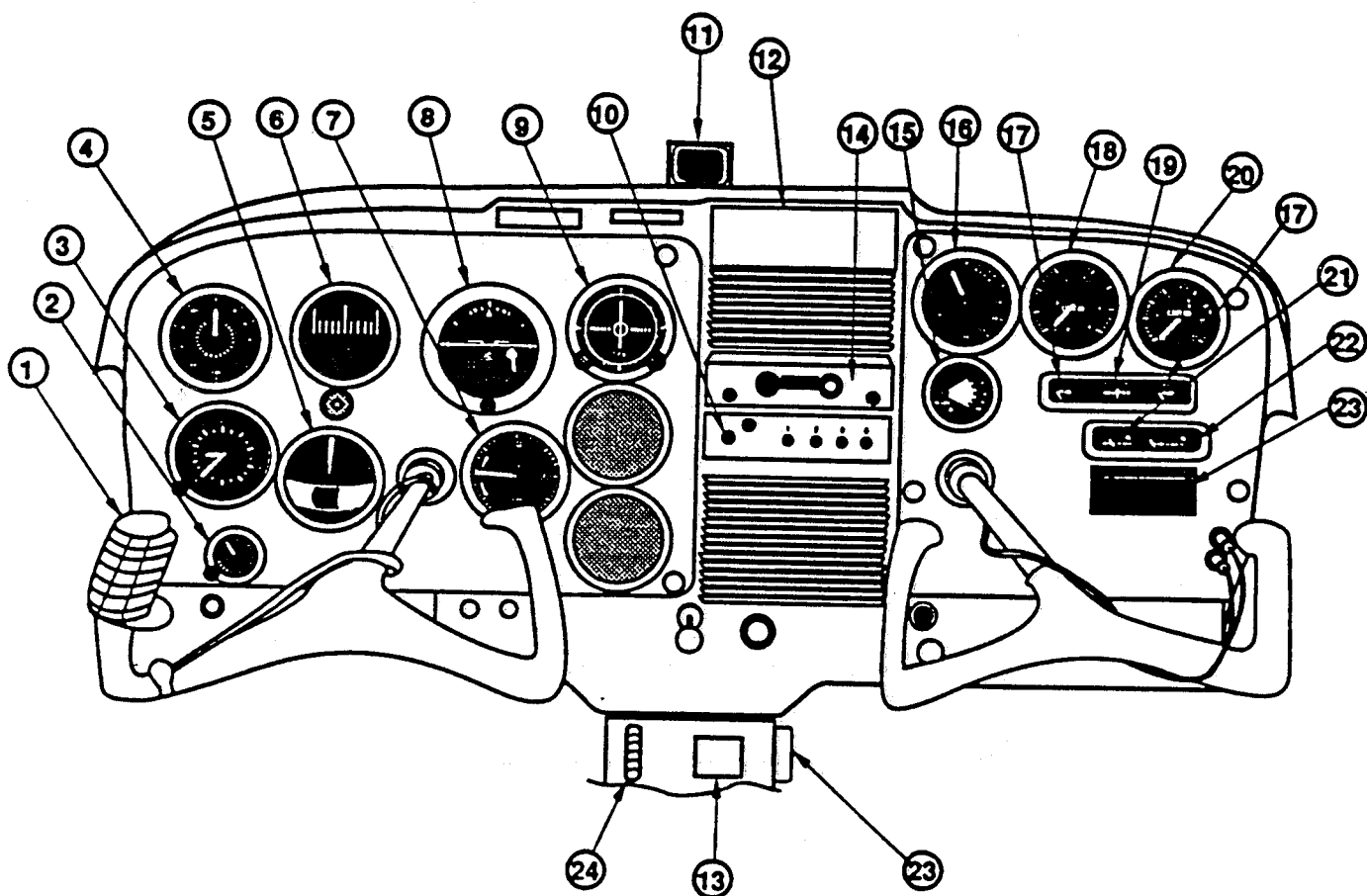

- 1. MIKE BUTTON (ON YOKE)
- 2. CLOCK
- 3. ALTIMETER
- 4. AIRSPEED INDICATOR
- 5. TURN & BANK INDICATOR
- 6. DIRECTIONAL INDICATOR
- 7. VERTICAL VELOCITY INDICATOR
- 8. ATTITUDE INDICATOR
- 9. VOR (NAV)

- 10. TRANSPONDER
- 11. MAGNETIC COMPASS
- 12. FREQUENCY PLACARD
- 13. CARBON MONOXIDE DETECTOR
- 14. RADIO
- 15. FLAP INDICATOR
- 16. FUEL FLOW INDICATOR
- 17. FUEL QUANTITY INDICATOR

- 18. TACHOMETER
- 19. AMMETER
- 20. SUCTION GAUGE
- 21. OIL TEMPERATURE INDICATOR
- 22. OIL PRESSURE INDICATOR
- 23. AUXILIARY MIKE JACK
- 24. TRIM TAB

Figure 1-4. Cockpit Forward View

From the mixture unit fuel flows to the fuel and air control unit. Air enters the fuel-air control unit from the air filter. Alternatively, if the air filter becomes clogged, suction from the engine opens a spring-loaded door, permitting air to be drawn from the engine compartment into the system. The throttle simultaneously controls the fuel and air valves in the fuel-air control unit delivering the correct ratio of fuel to the fuel distributor and air into the air-induction manifold. At the fuel distributor, fuel is evenly distributed to the cylinders through the fuel injection nozzles. Air from the induction manifold enters the cylinders through the intake valves. Fuel injection nozzles and the intake valves are installed on the top side of the cylinders. Drain lines are installed on the bottom of the intake ports to drain any fuel which may accumulate during engine shutdown or priming.

## Propeller

**D** The aircraft is equipped with an all metal, two-bladed, constant-speed, governor regulated propeller. Propeller operation is controllable by means of a propeller control knob which is mechanically linked to the engine-driven propeller governor on the engine. A setting introduced into the governor establishes the engine speed to be maintained, and the governor then controls flow of engine oil, boosted to high pressure by the governing pump, to or from the piston in the propeller hub. Oil pressure acting on the piston twists the blades toward high pitch (low RPM). When oil pressure from the governor to the piston is relieved, centrifugal force, assisted by an internal spring, twists the blades toward low pitch (high RPM).

The constant-speed propeller automatically keeps the blade angle adjusted for maximum efficiency for most conditions encountered in flight. During takeoff, when maximum power and thrust are required, the constant-speed propeller is at a low propeller blade angle or pitch. The low blade angle keeps the angle of attack small and efficient with respect to the relative wind. At the same time, it allows the propeller to handle a smaller mass of air per revolution. This light load allows the engine to turn at high RPM and to convert the maximum amount of fuel into heat energy in a given time. The high RPM also creates maximum thrust; for, although the mass of air handled per revolution is small, the number of revolutions per minute is many, the slipstream velocity is high, and with the low airplane speed, the thrust is maximum.

After lift-off, as the speed of the airplane increases, the constant-speed propeller automatically changes to a higher angle (or pitch). Again, the higher blade angle keeps the angle of attack small and efficient with respect to the relative wind. The higher blade angle increases the mass of air handled per revolution. This decreases the engine RPM, reducing fuel consumption and engine wear, and keeps thrust at a maximum.

After the takeoff climb is established the pilot reduces the power output of the engine to climb power by first decreasing the manifold pressure and then increasing the blade angle to lower the RPM.

At cruising altitude, when the airplane is in level flight and less power is required than is used in takeoff or climb, the pilot again reduces engine power by reducing the manifold pressure and then increasing the blade angle to decrease the RPM. Again, this provides a torque requirement to match the reduced engine power; for although the mass of air handled per revolution is greater, it is more than offset by a decrease in slipstream velocity and an increase in airspeed. The angle of attack is still small because the blade angle has been increased with an increase in airspeed.

The T-41C with its fixed-pitch propeller has only one main power control - the throttle. In that case, the setting of the throttle will control both the amount of power and the propeller or engine RPM.

## **D** Manifold Pressure & Engine RPM

On the other hand, the T-41D with its constant-speed propeller has two main power controls - the throttle and the propeller control. The throttle controls the engine's power output which is indirectly indicated on the manifold pressure gauge. The propeller control changes the pitch of the propeller blades and governs the RPM which is indicated on the tachometer. As the throttle setting (manifold pressure) is increased, the pitch angle of the propeller blades is automatically increased through the action of the propeller governor system. This increase in propeller pitch proportionately increases the air load on the propeller so that the RPM remains constant. Conversely, when the throttle setting (manifold pressure) is decreased, the pitch angle of the propeller blades is automatically decreased. This decrease in propeller pitch decreases the air load on the propeller so that the RPM remains constant.

For any given RPM, there is a manifold pressure that should not be exceeded. If an excessive amount of manifold pressure is carried for a given RPM, the maximum allowable pressure within the engine cylinders could be exceeded, placing undue stress on them. If repeated too frequently, this undue stress could weaken the cylinder components and eventually cause engine structural failure.

In order to avoid conditions that would possibly overstress the cylinders there must be a constant awareness of the tachometer indication, especially when increasing the throttle setting (manifold pressure). The combination to avoid is a high throttle setting (manifold pressure) and low RPM.

**WARNING**

Except during full throttle/prop FULL INCREASE operations such as takeoffs and go-arounds, never allow manifold pressure to exceed engine RPM.

When both manifold pressure and RPM need to be changed significantly, the pilot can further help avoid overstress by making power adjustments in the proper order. When power settings are being decreased, reduce manifold pressure before RPM. When power settings are being increased, reverse the order - increase RPM first, then manifold pressure.

**CAUTION**

If RPM is reduced before manifold pressure, manifold pressure will automatically increase and possibly exceed the manufacturer's tolerances.

## ENGINE INSTRUMENTS

### **D** Manifold Pressure Gauge

The left half of a dual indicating instrument located on the right side of the panel indicates induction air manifold pressure in inches of mercury. Manifold pressure is controlled by the throttle.

### Fuel Flow Indicator

Fuel flow is indicated by the right half of a dual indicating instrument located on the right side of the panel. It is a direct reading fuel pressure gauge, calibrated to indicate approximate gallons per hour of fuel being metered to the engine.

**D** Fuel flow will vary with throttle and propeller settings, but cruise fuel flow can be set with the mixture control knob.

**WARNING**

If the fuel flow gauge malfunctions, fuel or fuel fumes may enter the cockpit.

### **D** Cylinder Head Temperature

The cylinder head temperature gauge located on the right side of the instrument panel indicates number 3 cylinder head temperature in degrees Fahrenheit. The gauge is controlled by an electrical-resistance type temperature bulb which receives its power from the aircraft electrical system.

### **D** Propeller Control Knob

Control of engine RPM is accomplished by operation of the propeller control knob next to the throttle. Placing the knob in the full forward position decreases the blade angle and provides the highest RPM setting. Moving the control knob aft progressively increases the propeller blade angle and decreases engine RPM. Moving the control knob forward or aft to adjust RPM, is accomplished by rotating the knob clockwise to increase RPM or counter-clockwise to decrease RPM. If large or rapid changes are required, depress the lock button on the control knob and position the control forward or aft as required.

### Tachometer

The tachometer is a mechanical indicator driven by a flexible shaft connected to the oil pump shaft. The tachometer indicates engine speed in RPM X 100 (e.g., 12 = 1200 RPM).

### Oil Temperature Gauge

The oil temperature gauge is located on the right side of the instrument panel (figure 1-4). Heat

from engine oil causes the liquid in the line connecting the oil system and the gauge to expand. The gauge is direct reading and measures this expansion.

### Oil Pressure Gauge

A direct-reading gauge displays oil pressure in psi. It is located adjacent to the oil temperature gauge on the right instrument panel (figure 1-4).

#### WARNING

Should the oil pressure indication become abnormal in cold weather for no apparent reason, the problem may be condensation in the line from the system to the gauge. Turning the cabin heat off may correct the problem. However, be watchful for other signs of engine problems. In any case, declare an emergency and land as soon as practical.

### OIL SYSTEM

Oil for engine lubrication and cooling is supplied by a wet sump pressure splash gravity return system. The capacity of the sump is 10 US quarts. Oil is drawn from the sump through a low pressure filter screen into the engine-driven oil pump. A pressure relief valve in line from the oil pump automatically regulates pressure between 30 and 75 psi. When this valve opens it ports oil back to the sump reducing the oil pressure in the system. From the pump, oil is forced through a high pressure screen to a thermostat in the oil cooler. The thermostat opens and allows oil to bypass the oil cooler when the oil is cold. When the oil is hot, the thermostat closes causing the oil to be forced through radiator passages in the oil cooler, thus controlling engine oil temperature. Oil is then circulated to various engine parts for lubrication and returned to the sump by gravity flow.

The engine uses mineral oil for the first 100 hours to ensure better engine break in. After this break in period, the mineral oil is replaced with detergent oil. A white oil filler cap identifies an engine with mineral oil, a yellow filler cap indicates detergent

oil. An oil filler cap is located on the top side of the engine. The oil dipstick is located on the left side of the engine just above the oil cooler. Both the filler cap and the dipstick are accessible through the oil access door on the engine cowling.

### FUEL SYSTEM

Fuel is supplied to the engine from two 26-gallon tanks, one in each wing. Fuel from each tank flows by gravity to a three-position selector valve, labeled LEFT, BOTH, and RIGHT. Fuel then flows to a fuel reservoir tank and a manually operated fuel shutoff valve. A push-pull knob labeled FUEL, PUSH ON operates the shutoff valve (figure 1-2).

#### CAUTION

To prevent wear of the cable assembly, and to prevent a partially closed position of the fuel shutoff valve, the fuel shutoff valve should be left in the PUSH ON position, except during emergency engine shutdowns.

After passing through the fuel shutoff valve, the fuel is routed through a fuel strainer, located in the nosewheel compartment, and through a bypass check valve in the electric fuel pump (auxiliary fuel pump), when the pump is not being used. The fuel strainer is the lowest portion of the fuel system and is provided as a means of collecting any water that may have accumulated in the system. Any collected water will be drained overboard by pulling the fuel strainer knob located on the left lower switch panel. Additional water may also be drained through four valves (two beneath the forward fuselage and one on each wing root) with the use of a fuel sample cup. Fuel is then routed to the engine-driven fuel pump and mixture unit. From there, fuel is distributed to the engine via the fuel and air throttle unit and the fuel distribution manifold. Vapor and excess fuel from the engine-driven fuel pump and mixture unit are returned to the fuel reservoir tank. Due to gravity flow and fuel line placement, 1/2 gallon in each tank is not usable during straight and level flight; during maneuvering flight, 3 gallons in each tank are unusable (figure 1-7).

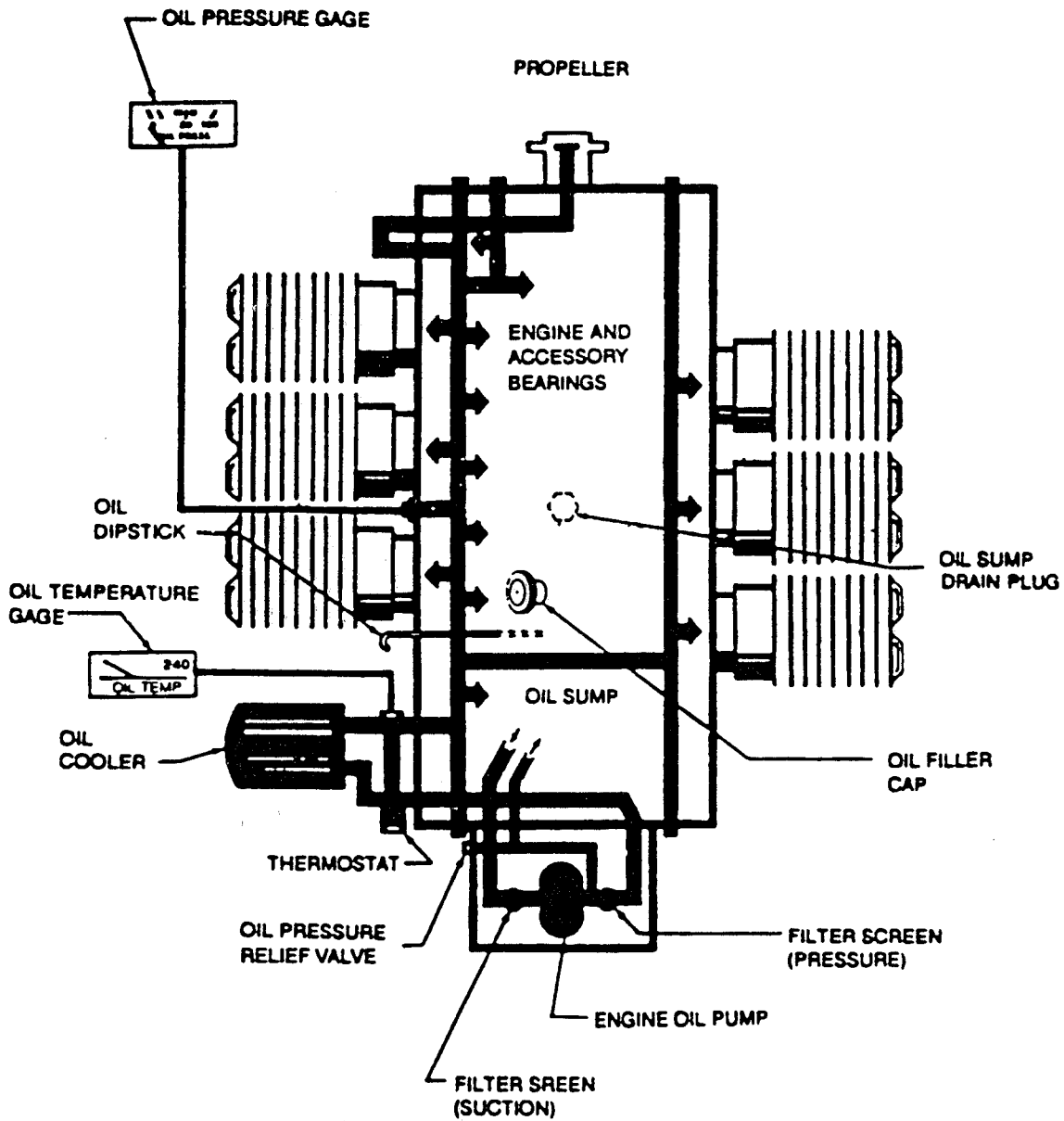

Figure 1-5. Oil System Schematic

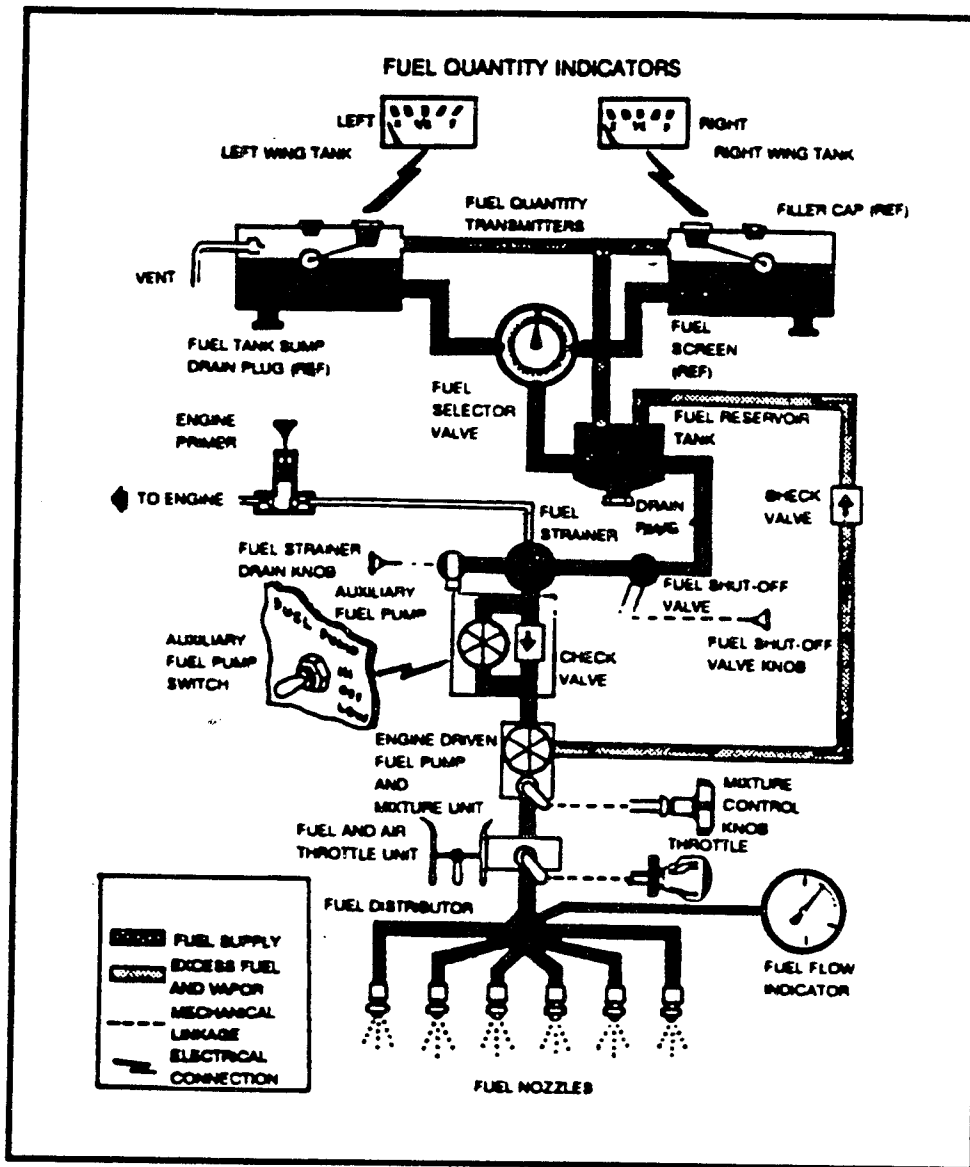

Figure 1-6. Fuel System Schematic

**NOTE**

- With the fuel selector valve on BOTH, the total usable fuel for all flight conditions is 46 gallons, and in level flight is 51 gallons.
- On 1969 model aircraft, the fuel strainer knob is located in the engine compartment and is accessible through the oil access door.
- On 1968 model aircraft, the fuel strainer knob is located on the instrument panel in the lower left corner.

**Engine-Driven Fuel Pump**

The engine-driven fuel pump has an aneroid which provides automatic fuel mixture for existing ambient conditions. It provides a more desirable fuel mixture control throughout the operational range, particularly at low and idle power settings.

The mixture unit is also an integral part of the engine-driven fuel pump controlling fuel flow through a mechanical linkage from the mixture control knob.



Should the aneroid in the engine-driven fuel pump fail, it will fail to the FULL LEAN position and use of the auxiliary fuel pump on LOW accompanied by manual leaning may be required.

**Auxiliary Fuel Pump**

An electric auxiliary fuel pump supplies fuel flow for starting and for engine operation following failure of the engine-driven fuel pump and for vapor purging. The auxiliary fuel pump switch (figure 1-2), located on the left lower switch panel, is a guarded, three-position, center-off switch. The down position, labeled LOW, operates the pump at one of two possible speeds depending on throttle position. With the throttle at a cruise setting and the auxiliary fuel pump switch in the LOW position, sufficient fuel flow is provided for cruise flight operation with a failed engine-driven fuel pump. When the throttle is moved towards the idle position, a microswitch is tripped which causes the auxiliary fuel pump flow rate to reduce,

thus preventing an excessively rich mixture during periods of low engine speed. The pump will switch to the alternate flow rate at a throttle setting of approximately 2100 rpm. The up position of the auxiliary fuel pump switch, labeled HIGH, operates the pump at its highest rate. The HIGH position is used for engine priming, for vapor purging during hot weather operations, or for alternate engine operation if the engine-driven pump should malfunction. The switch is spring-loaded to OFF from the HIGH position and must therefore be held in HIGH when used.

**NOTE**

If the auxiliary fuel pump switch is accidentally turned on with the master switch ON, the engine stopped, and the mixture control knob not at FULL LEAN, the cylinder intake ports will flood and fuel will drain overboard.

The auxiliary fuel pump is not used while the engine is running during normal operations. With the auxiliary fuel pump and the engine-driven fuel pump both functioning, an excessively rich fuel-air ratio will result.

**Manual Primer**

A manual primer, located on the left lower switch panel (figure 1-2), is provided to aid in starting the engine. It sprays fuel into the elbows of the engine induction manifolds for improved starts.

**Fuel Quantity Indicator**

The two electrically operated fuel quantity indicators are located on the right instrument panel (figure 1-4). The instruments indicate the fuel in the tanks from empty to full graduated in quarters. The indicators receive their inputs from fuel level transmitters in each wing tank any time the master switch is ON.

**NOTE**

Fuel quantity indicators are accurate only in stabilized straight and level flight.

**ELECTRICAL SYSTEM**

Electrical energy is supplied by a 14-volt, direct current system powered by a 60-ampere, engine-driven alternator. A 12-volt battery, located aft of



FUEL QUANTITY DATA (U.S. GALLONS)					
TANK	NO.	USABLE FUEL ALL FLIGHT CONDITIONS	ADDITIONAL USABLE FUEL (LEVEL FLIGHT)	UNUSABLE FUEL (LEVEL FLIGHT)	TOTAL FUEL VOLUME EACH
LEFT WING	1	23 gal.	2.5 gal.	0.5 gal.	26.0 gal.
RIGHT WING	1	23 gal.	2.5 gal.	0.5 gal.	26.0 gal.

Figure 1-7. Fuel Quantity Data (U.S. Gallons)

the rear cabin bulkhead, is used to supply electrical power for starting. It also serves as an alternate source of electrical power in case of alternator or regulator failure.

Power is supplied to all electrical circuits through a split bus bar (figure 1-8). The electronic bus contains the strobe lights, VHF radio, VOR receiver, transponder, and the pitot heat circuits. The primary bus contains all other electrical system circuits. With the master switch ON, both sides of the bus are normally powered. However, when either an external power source is connected, or the ignition switch is turned to START, a power contactor automatically deactivates the circuit to the electronic bus. Isolating the electronic circuits prevents transient voltages from damaging the semiconductors in the electronic equipment.

### Master Switch

The master switch controls electrical power to the aircraft electrical system. On 1968 model aircraft, the switch is a push-pull type and is located on the left lower switch panel (figure 1-2). On 1969 model aircraft, the master switch is a two-piece split switch which should be used as one switch during normal operations.

#### NOTE

On 1969 model aircraft, the split master switch may be beneficial during abnormal situations. The left switch serves to disconnect the alternator while the right side disconnects the battery.

### Ammeter

All aircraft are equipped with an ammeter that indicates the amount of current flowing either to or from the battery. The ammeter is located between the fuel quantity indicators on the right instrument panel (figure 1-4). Normally, the ammeter will remain within 0 to +2 needle widths if the alternator is operating properly and the battery is in a normal state of charge. Extreme charge or discharge rates for any duration are indications of an electrical system malfunction.

#### NOTE

A weak battery or a prolonged starting period may cause a high ammeter reading. This is normal; however, do not take off until the ammeter is within the normal range of 0 to +2 needle widths.

### External Power Receptacle

A ground service plug receptacle is installed to permit the use of an external power source for cold weather starting. The receptacle is located on the lower left side of the engine compartment, behind an access plate. The master switch should be ON before connecting an external power source.

### WARNING

Before starting the engine using an external power source, be sure that all ground personnel are well clear of the propeller danger area.

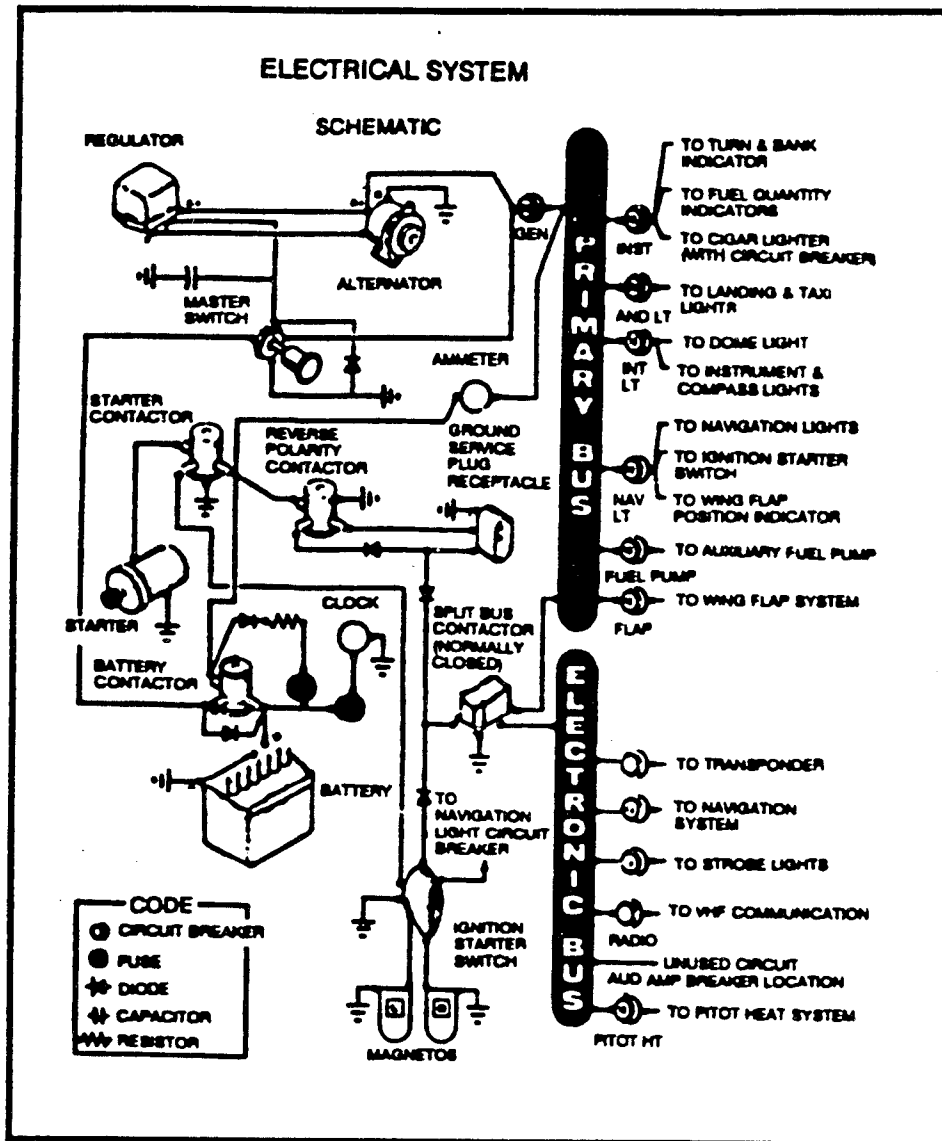

Figure 1-8. Electrical System Schematic

**CAUTION**

Use of other than a 12-volt power source may damage electrical systems. The ground service plug receptacle circuit incorporates polarity protection. Power from the external source will flow only if the service plug is connected to the aircraft properly.

**Circuit Breakers and Fuses**

The majority of electrical circuits in the aircraft are protected by "push to reset" circuit breakers located on the left lower switch panel (figure 1-2). Exceptions are the external power circuit and the clock circuit which are protected by fuses located near the battery.

**CAUTION**

If a circuit breaker pops out, it may be reset once if no other electrical malfunctions exist. If the circuit breaker pops out after being reset, do not attempt to reset it again. Terminate the mission and land as soon as conditions permit.

**NOSEWHEEL STEERING SYSTEM**

Nosewheel steering is accomplished through use of the rudder pedals. The nosewheel is steerable up to approximately 10 degrees each side of neutral, after which it becomes free wheeling to a maximum deflection of 30 degrees right or left of center when differential braking is used. A shimmy damper is provided to minimize nosewheel shimmy.

**BRAKE SYSTEM**

The hydraulic disc brakes on the main wheels are individually operated by applying toe pressure to the upper portion of either set of rudder pedals. Depressing the pedals activates the brake cylinders, resulting in a braking action on the main landing gear wheels. A master cylinder attached to each of the left seat (pilot) pedals transmits hydraulic pressure to the respective main wheel brake cylinder, thus applying brakes. The right seat brake pedals are connected by me-

chanical linkage to the pilot's brake pedals, and pressure applied to the right seat pedals is transmitted mechanically to the master cylinders.

**CAUTION**

If a sharper turn is desired than can be made with the rudder pedal steering mechanism, use the brakes to establish the rate of turn desired. While making a turn in this manner, keep the inside wheel rolling. Any attempt to pivot the aircraft on a locked inside wheel may damage the wheel, tire or strut. This is particularly dangerous because the damage may not be apparent. To make sure that the inside wheel rolls, release the inside brake intermittently. Apply the brakes smoothly, evenly, and cautiously at all times.

**Parking Brake**

The parking brake handle is located beneath the left lower switch panel (figure 1-2) and is used to set the brakes. The handle-and-ratchet mechanism is connected by a cable to linkage at the master cylinders. Pulling out the handle depresses both master cylinder piston rods and the ratchet locks the handle in this position until the handle is turned and released. To set the brakes, pull the parking handle out and turn it to the 6 o'clock position. To release the parking brake, rotate the handle 90 degrees clockwise to the 9 o'clock position and let it return to the original retracted position.

**WING FLAP SYSTEM**

The wing flaps are electrically operated and are controlled by a three-position switch on the right lower switch panel (figure 1-3). This switch, spring-loaded to the off position, controls an electric motor that raises or lowers the flaps by means of cables and push-pull rods. The motor is protected from shorts and overheat by a circuit breaker located on the circuit breaker panel. The electrically-operated flap position indicator is calibrated in degrees of flap extension from 0 to 40 degrees.

**CAUTION**

Holding the wing flap switch in the full up or down position for extended periods may cause the flap motor to overheat and the circuit breaker to pop.

## FLIGHT CONTROL SYSTEM

The aileron, elevator, and rudder control systems are comprised of push-pull rods, bellcranks, cables, and pulleys. The aileron and elevator systems are connected to the control wheel. The rudder system is connected to the rudder pedals.

Properly adjusted controls, when operated, move in the correct direction, are free of binding, and do not require excessive force for application.

**CAUTION**

Excessive force or abrupt control inputs may cause control system damage.

## Trim System

A trim tab is provided on the trailing edge of the right elevator to reduce control wheel forces and to allow hands-off flight at normal airspeeds. An elevator trim wheel, mounted in the center pedestal (figure 1-4), provides manual adjustment of the trim tab. The trim wheel and the adjacent pointer are labeled from top to bottom, NOSE DOWN, TAKEOFF, and NOSE UP. The pointer indicates the elevator trim position. Forward rotation of the wheel provides nose-down trim. Aft rotation provides a nose-up setting. Positioning the pointer abeam the white marker at the TAKEOFF label provides the normal takeoff trim setting.

## Control Lock/Gust Locks

When the aircraft is on the ground unattended, a control lock is used to lock the elevator and aileron control systems to prevent damage from wind gusts. The lock is designed to engage a hole in the pilot's control wheel shaft and instrument panel mounted bracket. A flag on the end of the control lock covers the ignition switch to warn against starting the engine with the lock installed. The rudder is protected from minor buffeting by the linkage between the nosewheel and rudder system.

External gust locks are also provided for all flight control surfaces for use when strong winds are expected.

**CAUTION**

Crew members should be sure the control wheel is properly positioned prior to installing the control lock. On 1969 model aircraft, the control lock should be removed prior to installing the gust lock on the elevator.

## STALL WARNING HORN

The stall warning horn is a pneumatic device, automatically activated by differential air pressure. The system includes an opening in the leading edge of the left wing, for sensing pressure, and a reed type horn located in the upper left side of the cabin. As the wing approaches a stall, airflow over the wing creates a low pressure condition in the area of the wing opening. This condition causes air to be drawn from the cockpit through the horn, resulting in an audible warning at airspeeds 5 to 10 mph above the stall in all configurations.

## INSTRUMENTS

The following paragraphs cover only those instruments which are not part of a complete system such as the fuel system, engine, etc. The flight instruments consists of an airspeed indicator, vertical velocity indicator, altimeter, turn-and-slip indicator, attitude indicator, heading indicator, magnetic compass, and clock. All flight instruments are located in the left instrument panel directly in front of the pilot (figure 1-4), except the magnetic compass which is located on the top of the dash panel.

## Pitot-Static System and Instruments

The pitot-static system supplies air pressure to operate the airspeed indicator. The static portion of the system supplies the operating pressures for the vertical velocity indicator, altimeter, and airspeed indicator. The pitot-static system is composed of an electrically heated pitot tube mounted under the left wing, two external static ports, located on either side of the aircraft fuselage, and the associated plumbing necessary to connect the instruments to their sources.

## Pitot Heat

A push-pull pitot heat switch, labeled PITOT HEAT, is located on the left lower switch panel (figure 1-2).

When the switch is placed in the ON position, the pitot tube is electrically heated. Pitot heat is provided for flight in areas of visible moisture.

### WARNING

The pitot tube becomes very hot without cooling airflow. To prevent burn injury to ground personnel, the pitot heat switch should be OFF during ground operations.

## Airspeed Indicator

The airspeed indicator is operated by pitot and static pressures sensed by the pitot-static system. Airspeed is indicated in miles per hour.

### WARNING

Slips may result in airspeed errors. Also, large errors in indicated airspeed will occur near stalling speed.

## Vertical Velocity Indicator (VVI)

The vertical velocity indicator depicts aircraft rate of climb or descent up to 2,000 feet per minute. The pointer is actuated by an atmospheric pressure change sensed through the static ports.

### WARNING

The pointer does not stop at the 2,000 ft/min rate of deflection. A climb in excess of 2,000 ft/min could be indicated as a descent on the VVI, and vice versa.

## Altimeter

The altimeter is a barometric type instrument which operates on static pressure. A barometric pressure set knob on the lower left corner of the

indicator provides adjustment of the barometric scale for changes in atmospheric pressure. The short needle indicates thousands of feet while the long needle indicates hundreds of feet.

## Turn-and-Slip Indicator

The turn-and-slip indicator is composed of a turn needle and an inclinometer. The principal functions of the turn-and-slip indicator are to provide an alternate source of bank control, and to indicate rudder coordination. The turn needle, driven by an electrical gyro, indicates the rate of heading change and direction of turn. The inclinometer, a ball in a liquid filled glass tube, indicates coordination. Gravity and centrifugal force act on the ball. When the aircraft is in coordinated flight, the ball will be centered.

## Vacuum System

Suction to operate the heading indicator and attitude indicator gyros is provided by an engine-driven vacuum pump. The vacuum pump is mounted on the engine accessory case. A suction relief valve is used to control system pressure. The suction gauge, located on the right instrument panel (figure 1-4), is calibrated in inches of mercury and indicates the suction available for operation of the attitude and heading indicators.

### NOTE

System leaks or other malfunctions may be indicated by abnormal suction gauge readings and may cause incorrect indication of attitude and heading.

## Attitude Indicator

The vacuum-powered attitude indicator gives a gyro stabilized visual indication of aircraft attitude. The indicator is reliable through 60 degrees of climb and dive and 100 degrees of bank. Bank is presented by a bank pointer relative to a bank scale. This scale is marked with degree indices.

The horizon bar provides sensitive reference near a level flight altitude. A pitch trim knob is included to adjust the miniature aircraft in relation to the horizon bar. A caging knob facilitates rapid manual erection of the gyro. If it is necessary to uncage the gyro in flight, the aircraft should be straight-and-level. On 1969 model aircraft there are no provisions for caging the attitude indicator.

## Heading Indicator

The vacuum-powered heading indicator displays aircraft heading. The indicator is reliable through 55 degrees of dive, climb, and bank. On 1968 aircraft, a caging knob allows caging of the gyro during maneuvers beyond the limits of the gyro. On 1969 model aircraft there are no provisions for caging the heading indicator.

## Magnetic Compass

A magnetic compass is centrally mounted on top of the glare shield. The compass is liquid filled, free floating, and reliable only in straight-and-level unaccelerated flight.

### NOTE

Use of the landing/taxi light causes erroneous indications in the magnetic compass due to the creation of an electromagnetic field. Do not use the magnetic compass to reset the heading indicator when the landing/taxi light is on, or when headsets are placed near the magnetic compass.

## Clock

The clock is electrically operated and is on at all times. The setting knob is located on the lower left side of the instrument panel.

## COMMUNICATIONS/NAVIGATION EQUIPMENT

### Interphone System

The interphone system consists of microphone buttons, located on each control wheel, and headsets. On four-seat aircraft, a third interphone headset is provided for use by a rear seat passenger. The system allows unrestricted communication within the aircraft communication beyond the aircraft by integration with the radio equipment, and monitoring of radio and NAVAID signals. The system is powered by the electrical system and is activated by the radio function switch.

### NOTE

The only volume control on the interphone system is on the headset. Transmission volume can be adjusted only by varying the distance between the microphone boom

and your mouth. Headset volume should be set prior to adjusting radio volume.

## Overhead Speaker System

An overhead speaker and hand-held microphone are provided should the headsets system fail. The microphone is stored in the map case on the right instrument panel. A jack to plug in the microphone and a toggle switch to turn on the overhead speaker are located on the right side of the center pedestal. The toggle switch, when placed in the up position, activates the speaker.

### NOTE

Feedback through radio and/or interphone may be heard if the headset is used or plugged in when the overhead speaker switch is turned on.

## VHF Radio

A Narco Com 120 transistorized radio provides VHF communications capability (figure 1-9). The radio has line-of-sight reception and provides voice transmission and reception on 720 frequencies in the range of 118.000 to 135.975 MHz by 0.025 MHz increments. The large control knobs on either side of the frequency readout window control frequency selection. To activate the radio, turn the function switch clockwise to ON.

### NOTE

No warmup time is required for the Com 120 radio due to its 100 percent solid state design.

To test the radio, rotate the function switch clockwise to TST. This position disables the unit's automatic squelching circuitry and allows the characteristic "rush sound" of unsquelched receiver audio to be heard. The "rushing sound" indicates electrical power is present and key elements are operating properly. Volume is controlled by a small knob marked VOLUME. Rotating the knob clockwise will increase the volume and counterclockwise will decrease the volume. The small amber light, located below the frequency readout window, is a transmit-monitor light and illuminates when the transmitter is activated. The light varies in brightness to indicate transmitter strength.

## VOR Receiver

A Narco Nav 121 transistorized VOR receiver provides VOR navigation capability (figure 1-10). The VOR unit has line-of-sight reception and may be tuned in the frequency range of 108.00 to 117.95 MHz by 0.05 MHz increments. The concentric knobs, in the lower right corner of the instrument, control the frequency selection.

To activate the unit, turn the function knob, located in the upper right corner of the instrument, clockwise until it clicks on.

### NOTE

No warmup period is required for the Nav 121 unit due to its 100 percent solid state design.

To identify a VOR station, pull out the function knob and rotate it clockwise until the audio signal can be heard. To select a VOR course, rotate the knob in the lower left corner of the instrument until the desired course appears beneath the vertical index line, located at the 12 o'clock position on the instrument. The course deviation from the selected course, appearing under the vertical index. A TO/FROM indicator shows whether the selected course, if flown, would take the aircraft to or from the station.

### NOTE

A red flag labeled NAV will appear in place of the TO/FROM if:

- The course selected is perpendicular to the course to the station.
- Signal reception is too weak.
- The aircraft flies over the station (during station passage).
- The Nav 121 unit is turned off.

To test the unit, select a nearby VOR station, rotate the course selection knob until either 0 degrees or 180 degrees is under the vertical index, then push the course selection knob in and hold it for a few seconds. The course deviation indicator needle should center and the TO/FROM indicator should show TO if 0 degrees was selected or FROM if 180 degrees was selected.

## Transponder

A Narco AT 150 transistorized transponder provides positive radar identification to ground agencies and is capable of responding to interrogations on any of 4096 codes (figure 1-11). These codes are selected by rotating the four, eight-position code selector knobs.

A five-position, rotary function switch activates and controls unit operation. The five positions are:

**OFF.** Turns off all power to the transponder.

**SBY (Standby).** Turns the transponder on for warmup but does not reply to any interrogations. (Warmup requires 20 seconds.)

**ON.** The transponder will respond to any interrogation.

**ALT (Altitude).** Operates the same as the ON mode. Altitude reporting Mode is operational.

**TST (Test).** Causes an internal test signal to be generated which illuminates the reply lamp. This position is spring-loaded to ALT.

The IDENT push-button is used to reply to an agency when asked to "Squawk IDENT." Momentarily depressing the button will activate a special signal for approximately 20 seconds and will illuminate the reply lamp, located within the IDENT push-button, for the duration of the special signal. During normal operation, the reply lamp will blink whenever the transponder is being interrogated. Rotate the button to control reply lamp brightness.

## LIGHTING

All exterior and interior lighting is controlled from within the cabin. Exterior lighting equipment consists of navigation lights, landing and taxi lights, and strobe lights. The switches for these lights are located on the left lower switch panel beneath the control wheel (figure 1-2), and are of the pull-on, push-off type. Interior lighting is composed of instrument and radio control panel lights and a cabin dome light. The switches for the interior lights are located on the ceiling console.

## Navigation Lights

Conventional red (left), and green (right), navigation lights are mounted on the wingtips. A white

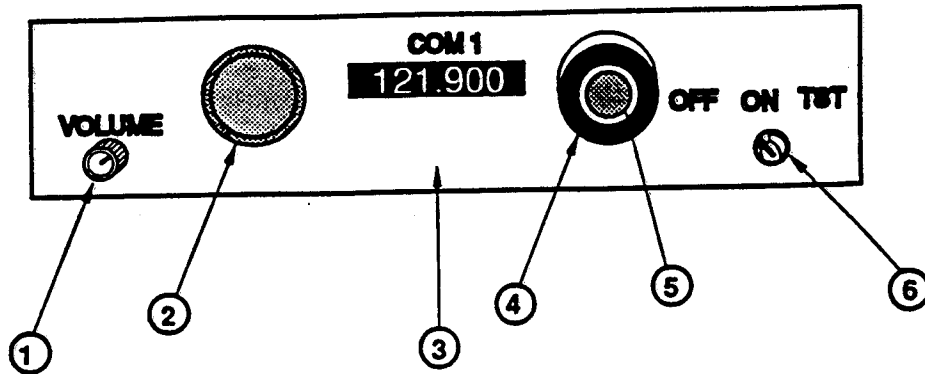

- |                                   |                                  |
|-----------------------------------|----------------------------------|
| 1. Volume Control                 | 4. Frequency Selector (.X MHz)   |
| 2. Frequency Selector (Whole MHz) | 5. Frequency Selector (.OXX MHz) |
| 3. Transmit Indicator             | 6. Function Switch               |

Figure 1-9. VHF Radio

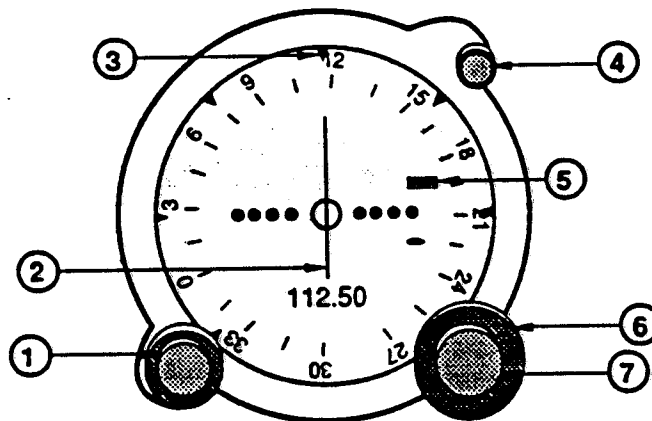

- |                               |                                   |
|-------------------------------|-----------------------------------|
| 1. Course Selector/Test Knob  | 5. TO/FROM Indicator              |
| 2. Course Deviation Indicator | 6. Frequency Selector (Whole MHz) |
| 3. Vertical Index Line        | 7. Frequency Selector (.XX MHz)   |
| 4. Function Switch            |                                   |

Figure 1-10. VOR Receiver



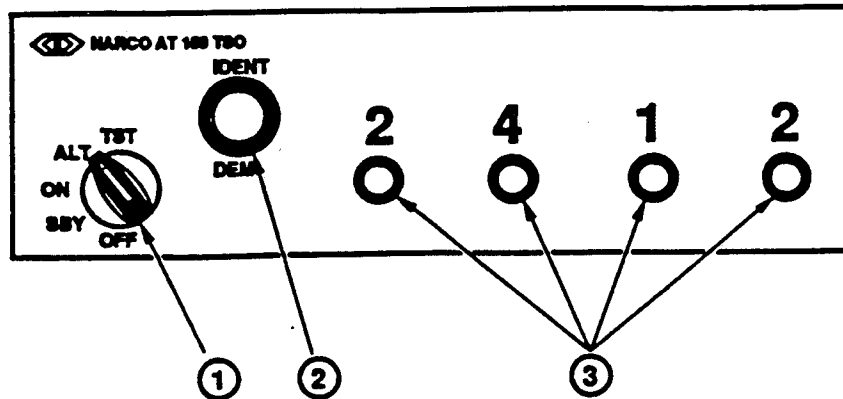

1. Function Switch
2. IDENT Push-Button/Reply Lamp
3. Code Selectors

Figure 1-11. Transponder

navigation light is mounted on the upper aft portion of the vertical stabilizer.

### Landing and Taxi Lights

Landing and taxi lights are located in the leading edge of the left wing. The taxi light is focused to provide illumination of the area forward of the aircraft during ground operation and taxiing. The landing light is focused to provide illumination forward and downward during takeoff and landing. Pulling the landing/taxi light switch out one click turns on the taxi light, while pulling it out all the way illuminates both the landing and the taxi lights. Both lights are high intensity and require cooling airflow for continuous operation.

#### CAUTION

Excessive use of the landing/taxi lights, while on the ground may damage the protective lenses.

### Strobe Lights

A strobe light is located in each wingtip next to the position light and on the top of the vertical stabilizer.

#### WARNING

The strobe lights produce intense light and heat. Do not look directly into operating lights, or touch bulbs during or immediately after operation.

### Interior Lighting

Interior instrument and radio lighting is controlled by a rheostat located above the seats on the cabin ceiling. The rheostat on the right side controls instrument lights; the rheostat on the left side controls radio lighting. The cabin dome light is located behind the rheostat unit and is controlled by an on-off switch located adjacent to the light.

### CABIN HEATING AND VENTILATION SYSTEM

Cabin heat, defrosting, and ventilation are provided by manifold heaters, ducting, and valves which allow the entry of heated or unheated air to the cabin. The cabin heat knob, located on the right lower switch panel (figure 1-3), controls the amount of heat supplied to the cabin. The full out

position provides maximum heating and defrosting. The cabin air knob (figure 1-3), controls the amount of fresh air entering the cabin from the air scoop door on the forward right side of the fuselage. The full out position provides maximum fresh air. Separate adjustable ventilators near each upper corner of the windshield supply additional fresh air.

### WARNING

The exhaust system is subject to cracking and deterioration. If the cabin heat is used and the exhaust heat exchanger is defective, carbon monoxide will enter the cabin. Do not use cabin heating without cabin air or ventilators open to supply a source of fresh air.

### Carbon Monoxide Detector

A small carbon monoxide detector is located on the center pedestal (figure 1-4). On the lower center of the detector is an indicator that is sensitive to carbon monoxide. If carbon monoxide is introduced into the cabin, the indicator will darken.

### WARNING

Should the indicator on the carbon monoxide detector become dark, proceed with the Smoke and Fume Elimination procedure in your checklist.

### CABIN DOORS

Cabin doors are located on each side of the cabin. They incorporate an exterior door handle, interior three-position door handle (open, closed, locked), and a door stop mechanism. The left door has a movable window. The right door has a fixed window.

### Cabin Door Movable Window

The movable window in the left cabin door is hinged at the top. The window is secured by a latch handle located on the bottom edge. When locking the window, the button should pop out as the latch handle is rotated to the closed position.

### CAUTION

Unlocking the window without depressing the button will cause internal damage to the latch.

### SEAT OPERATION

The seats are fore and aft adjustable, with manually operated reclining seat backs. The fore and aft adjustment levers are located under the left front of each seat. On 1968 model aircraft, the manual releases for the seat backs are located on the right rear corner of each seat. On 1969 model aircraft, the release for the seat back is located under the right front of each seat. Rollers permit the seats to slide fore and aft on seat rails. Pins which engage various holes in the seat rails lock the seats in the selected positions. A seat stop limits travel of the left seat.

### SEAT BELTS AND SHOULDER HARNESSSES

Seat belts and shoulder harnesses are provided for both front seats. The rear seat, on four-seat models, is equipped with seat belts only. The shoulder harnesses are attached to cables which are routed to inertia reels located on the cabin side walls just aft of the rear door posts near floor level. A two-position control lever is mounted on the left side of each seat to control the operation of the inertia reels. The aft position is labeled AUTOMATIC. When the control lever is placed in the AUTOMATIC position, the shoulder harnesses will permit free movement fore and aft, as long as a sudden forward movement is not attempted. Sudden forward movement will lock the inertia reel and permit only aft movement. To unlock the reel, the control lever must be cycled to MANUAL, then back to AUTOMATIC. Placing the control lever in the forward position, labeled MANUAL, will lock the shoulder harness at the existing position. With the control lever in the MANUAL position, the inertia reel will allow aft movement only.

### NOTE

Seat adjustment may be difficult if the seat belts and shoulder harness are tightened prior to adjusting the seat.

## SECTION II

## NORMAL PROCEDURES

## Table of Contents

Introduction .....	2-1
Interior Inspection .....	2-1
Exterior Inspection .....	2-2
Before Starting Engine .....	2-4
Starting Engine .....	2-4
Before Taxiing .....	2-6
Taxiing .....	2-6
Before Takeoff .....	2-6
Takeoff .....	2-8
After Takeoff .....	2-9
Climbs .....	2-9
Level Off .....	2-9
Before Descent .....	2-10
Approach to Field .....	2-10
Before Landing .....	2-10
Landing .....	2-12
Go-Around .....	2-13
Touch-and-go Procedures .....	2-14
After Landing .....	2-14
Engine Shutdown .....	2-14
Before Leaving Aircraft .....	2-15

## INTRODUCTION

Visual inspection of the aircraft is a very important part of each mission. Start your preflight inspection as you approach the aircraft. Look at the overall aircraft condition, chocks, tiedowns, and any unusual wet spots under the aircraft which may indicate leaks. Look at the proposed taxiing routes for any possible obstruction such as ground repair work, fire extinguishers on the ramp, or other equipment that could cause a taxi accident.

The checklist outlines procedures but never takes the place of good judgment. Checklist items preceded by an asterisk (\*) are challenge response items.

## INTERIOR INSPECTION

## 1. AFTO Form 781 - CHECK

The AFTO Form 781 is the official log of aircraft operation, refueling, and maintenance. Do not accept an aircraft unless the Form 781 properly indicates the aircraft status and that the aircraft has been cleared for flight.

2. Required Publications- ON BOARD.
3. Parking Brake - SET.
4. Control Lock - REMOVE.



Allowing the control wheel to slam forward when removing the control lock could cause damage to the controls and/or instrument panel.

5. Master Switch - OFF.
6. Ignition Switch - OFF.

A worn switch may appear to be off when it is not. Physically ensure the switch is in the off detent.

7. Auxiliary Fuel Pump Switch - GUARDED.
8. Primer- LOCKED.
9. Fuel Shutoff Knob - IN.

- 10. Circuit Breakers - IN.
- 11. Carbon Monoxide Detector - CHECK.
- 12. Trim - SET at TAKEOFF.
- 13. Fuel Selector - BOTH.
- 14. Master Switch - ON.

**WARNING**

Clear the propeller area prior to turning the master switch ON in case of a starter malfunction.

- 15. Fuel Quantity - CHECK gauge readings. The fuel quantity should agree with the AFTO Form 781.
- 16. Lights and Pitot Heat - CHECK (except strobe).
- 17. Master Switch - OFF.
- 18. Fuel Strainer Knob (1968 models) - CHECK (pull out for 4 seconds, cross-country only; ensure knob is all the way in).
- 19. Loose Articles - SECURE.

**EXTERIOR INSPECTION**

During the exterior inspection, note the condition of all aircraft surfaces, antennas, and the security of all access panels. In addition, control surfaces should be checked for clearance, security of attachment and actuator bolts, and the condition of hinges, rollers, slides, actuator cables, counter weights, etc.

- A. Tiedowns, gust locks, grounding wire, pitot tube cover- REMOVE.
- B. Left Main Landing Gear Section.
  - 1. Chock - REMOVE.
  - 2. Tire - CHECK inflation, cuts, or blisters and that the hub cap is secure. If any cord is showing, the tire is worn beyond limits and should be changed.
  - 3. Brake Assembly - CHECK brake pucks for thickness (minimum 3/32 inches) and brake lines for security and leakage.
  - 4. Fuel Sump - Drain

C. Left Wing Section.

- 1. Flap - CHECK.
- 2. Aileron - CHECK.

**WARNING**

If placing fingers within the slot between the aileron and wing, be sure aileron is physically held against wind gust pressure.

- 3. Strobe/Navigation lights - CHECK condition.
- 4. Landing/Taxi Lights - CHECK casing and security
- 5. Stall Warning Horn - CHECK for obstructions.
- 6. Fuel Vent - CHECK for obstruction and excessive leakage.
- 7. Pitot Tube - CHECK inlet and drain holes for obstructions.

**CAUTION**

The pitot tube should be visually inspected only. Improper handling may misalign the pitot tube, causing incorrect airspeed indications.

D. Engine Section. *8. Check Fuel quantity, Cap Secure*

- 1. Oil Quantity CHECK. Secure Dipstick.

**CAUTION**

Do not operate the engine with less than 6 quarts of oil. Minimum oil quantity for normal flights of less than 3 hours is 7 quarts, and 8 quarts for flights of 3 hours or greater.

- 2. Oil Cap - SECURE.
- 3. Fuel Strainer Knob (1969 models) - CHECK (pull out for 4 seconds, cross-country only; ensure knob is all the way in).

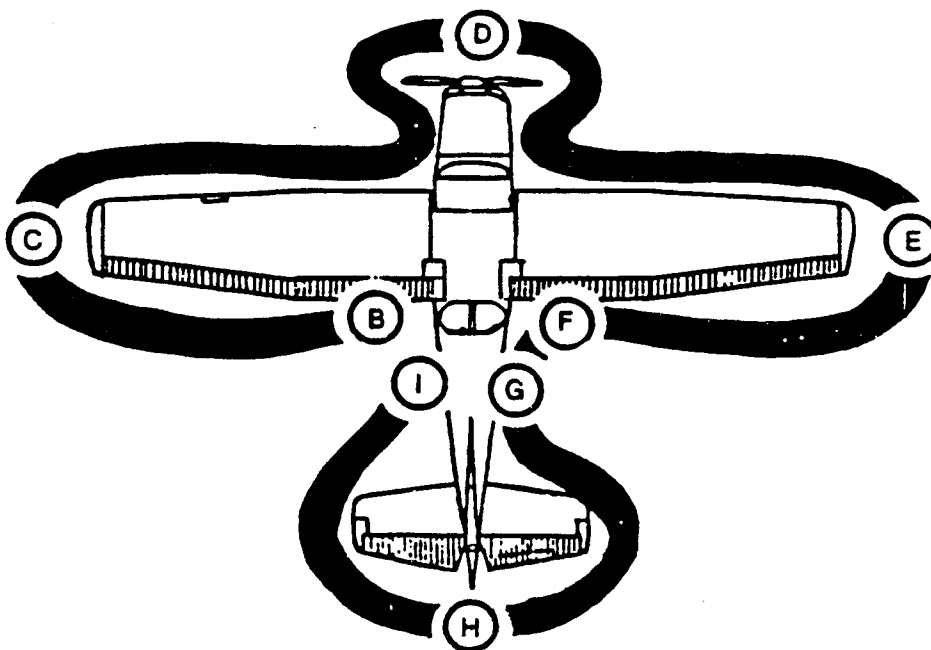

Figure 2-1. Exterior Inspection

4. Access Door - SECURE.
5. Nose Strut - CHECK. Nose gear strut extension should be 1 inch minimum to approximately 3 inches. Excessive strut extension can normally be corrected by lifting slightly on the fuselage near the horizontal stabilizer. The nose gear strut should be clean and free of hydraulic leaks. The shiny machined surfaces should be free of dust and dirt.
6. Nose Tire - CHECK.
7. Propeller - CHECK for nicks (  $\frac{1}{8}$  inch maximum) or damage.
8. Propeller Seal Plug - CHECK for evidence of oil leakage.
9. Nosewheel Compartment - CHECK for leakage from the fuel strainer valve or excessive oil/fuel leakage from other lines.
10. Low point Drains - Drain(2)
- E. Right Wing Section.  
*CHECK FUEL QUANTITY, CAP SECURE*
  1. Strobe/Navigation Lights - CHECK.
  2. Aileron - CHECK.
  3. Flap - CHECK.
- F. Right Main Landing Gear Section.
  1. Chock - REMOVE.
  2. Tire - CHECK.
  3. Brake Assembly - CHECK.
  4. Fuel Sump - Drain
- G. Right Fuselage Section.
  1. Static Port - CLEAR.

**WARNING**

Stay clear of propeller danger area and do not hand turn the propeller

**CAUTION**

Check visually only. Rubbing your finger across the static port may introduce dirt into the static pressure system resulting in erroneous flight instrument indications.

- H. Tail Section.
  1. Trim Tab Alignment - CHECK within  $\frac{1}{4}$  inch of the elevator with the bottom of the

elevator horn flush with the bottom of the horizontal stabilizer.

2. Right Elevator - CHECK.
3. Rudder - CHECK.
4. Rudder and Elevator Cables - CHECK.

Control cable bolts for the rudder and elevator should be checked to ensure they are properly installed and are not binding or rubbing when these control surfaces are moved. Avoid moving control surfaces using trim tabs.

5. Navigation Light - CHECK.
6. Fuel Caps - CHECK.
7. Left Elevator - CHECK.

I. Left Fuselage Section.

1. Static Port - CLEAR.
2. Battery Drain - CHECK visually for leakage.
3. Baggage Door - SECURE, closed and locked.

**BEFORE STARTING ENGINE**

1. Parking Brake - SET.
2. Seat - ADJUST AND LOCK.

**WARNING**

Be sure seats are locked in position prior to flight, or they may inadvertently move in flight.

3. Seat Belt and Shoulder Harness - FASTEN.

**WARNING**

Seat belts should be checked for proper routing to ensure you are secure. The seat belt could hang up on the seat back reclining lever and appear secure, but not hold the pilot securely. The shoulder

harness inertia reel should also be checked for binding and proper operation.

4. Heading Indicator - CAGE (1968 models).
5. Attitude Indicator - CAGE (1968 models).
6. Cockpit Air and Heat Knobs - CLOSED.
7. Flight Controls - CHECK for free and proper movement.

**STARTING ENGINE**

1. Mixture - RICH.
2. **D** Propeller - Full Increase
3. Master Switch - ON.

**WARNING**

Clear the propeller area prior to turning the master switch on in case of a starter malfunction.

4. Navigation Lights - ON.
5. Auxilliary Fuel Pump Switch - HIGH.
6. Throttle - SET for 8-10 gal/hr fuel flow.
7. Auxilliary Fuel Pump Switch - RELEASE.
8. Throttle - IDLE, then IN, 1/4 to 1/2 inch.
9. Clear the area around the aircraft 360 degrees. - CALL "CLEAR".
10. Auxilliary Fuel Pump Switch - AS REQUIRED. Usually OFF. However, LOW may facilitate starting a hard to start engine.
11. Ignition Switch - START, release when engine starts.

**NOTE**

The engine should start in two to three revolutions. If it does not, one of the following situations most likely exists:

- I. Excessively lean Mixture:
  - a. Symptom - engine starts, but quits in 3 to 5 revolutions.

- b. Cause - Insufficient priming.
- c. Corrective action - apply additional primer strokes and/or switch auxiliary fuel pump on LOW or HIGH as required before cranking is started.

**CAUTION**

Limit use of the auxiliary fuel pump to prevent overpriming and flooding. Excessive cranking will rapidly drain a cold-soaked battery.

II. Excessively Rich Mixture:

- a. Symptom - Engine mis-starts characterized by intermittent explosions and puffs of black smoke.
- b. Causes - Overpriming or flooding. More apt to occur in hot weather.
- c. Corrective Action:
  - 1) Crank engine with throttle approximately halfway in, the mixture at FULL LEAN, and the auxiliary fuel pump OFF.
  - 2) Push mixture to RICH as engine starts.

III. Fuel Line Vapor Locked:

- a. Symptom - Engine will not start.
- b. Causes - Vaporized fuel in engine-driven pump or fuel lines. More apt to occur in hot weather with hot engine.
- c. Corrective Action:
  - 1) Mixture - FULL LEAN.
  - 2) Throttle - IDLE.
  - 3) Aux Fuel Pump - HIGH for 5-10 seconds.

- 4) Attempt normal start.

**NOTE**

If the engine does not start during the first few attempts, turn the ignition and master switch OFF to prevent excessive drain on the battery. Call for maintenance assistance.

- 12. Auxiliary Fuel Pump Switch - OFF and GUARDED.

- 13. Throttle - 1000 RPM minimum.

**CAUTION**

Excessive RPM during ground operations may result in FOD damage to the propeller, stabilizer, or other aircraft.

**NOTE**

A throttle setting of at least 1,000 RPM while stopped on the ground aids in engine cooling, lubrication, and prevents spark plug fouling.

- 14. Engine Instruments - CHECK.

**NOTE**

- The oil pressure gauge should show a positive indication within 30 seconds of engine start.
- **D** It may take several seconds longer than the T-41C for an oil pressure indication due to the increased routing and demand for engine oil through the governor. However, the oil pressure gauge should show a positive indication within 30 seconds of engine start (1 minute when the temperature is below 0°F).

**BEFORE TAXIING**

1. Radio - ON.
2. Transponder - STANDBY.
3. VOR - AS REQUIRED (On for navigation sorties only).
4. Clock - SET.
5. Flight Instruments- CHECK.
  - a. Altimeter. CHECK and SET. Set current altimeter setting and check within 75 feet of known elevation.
  - b. Airspeed Indicator. CHECK pointer for proper indication.
  - c. Magnetic Compass. CHECK for accuracy of the heading information, cracks in the glass, bubbles in the fluid, and that the compass is free floating.
  - d. Heading Indicator. SET (and UNCAGE if applicable).
  - e. Attitude Indicator. UNCAGE (if applicable). Set the miniature aircraft on the artificial horizon and check the bank pointer aligned with the 0-degree bank index.
  - f. Vertical Velocity. CHECK pointer for proper indication.
6. Flaps - CHECK, for proper operation of both flaps and the indicator.
7. Radio - CHECK.  
The call to ground for taxi serves as the radio CHECK.
8. Parking Brake - RELEASE.

**WARNING**

Prior to and during all taxi operations, flight control should be positioned for winds (see figure 2-2).

**AXIING**

1. Brakes - CHECK proper operation when pulling out of the chocks. The aircraft need

not be brought to a complete stop to adequately check the brakes.

2. Turn-and-Slip Indicator - CHECK the turn needle and ball for proper indication.

**BEFORE TAKEOFF**

- Fuel Selector - Both*
1. Throttle - 1800 RPM.

**CAUTION**

Use caution for aircraft "creeping" during the check. Ensure proper clearance on aircraft beside, in front of, and behind you.

2. Engine Instruments and Suction Gauge - CHECK.
3. Ignition System - CHECK:
  - a. Ignition Switch - RIGHT. Check the amount of RPM drop, then return to BOTH. Ensure RPM returns to 1800.
  - b. Ignition Switch - LEFT. Check the amount of RPM drop, then return to BOTH, ensure RPM returns to 1800.

**CAUTION**

If the ignition switch is accidentally turned to the off position, leave it in the off position and retard the throttle to idle. Once the propeller has stopped restart the engine.

**NOTE**

Maximum allowable RPM drop is 150, with a maximum difference between magneto drops of 50 RPM. If no RPM drop or an excessive RPM drop is noted, the aircraft should be aborted.

4. **D** Propeller - Cycle and SET FULL INCREASE. With the power set at 1800 RPM and propeller control at FULL INCREASE, pull the propeller to DECREASE RPM by depressing the lock button on the control knob and check for an RPM drop. Return the propeller control to FULL INCREASE as soon as RPM begins to drop.



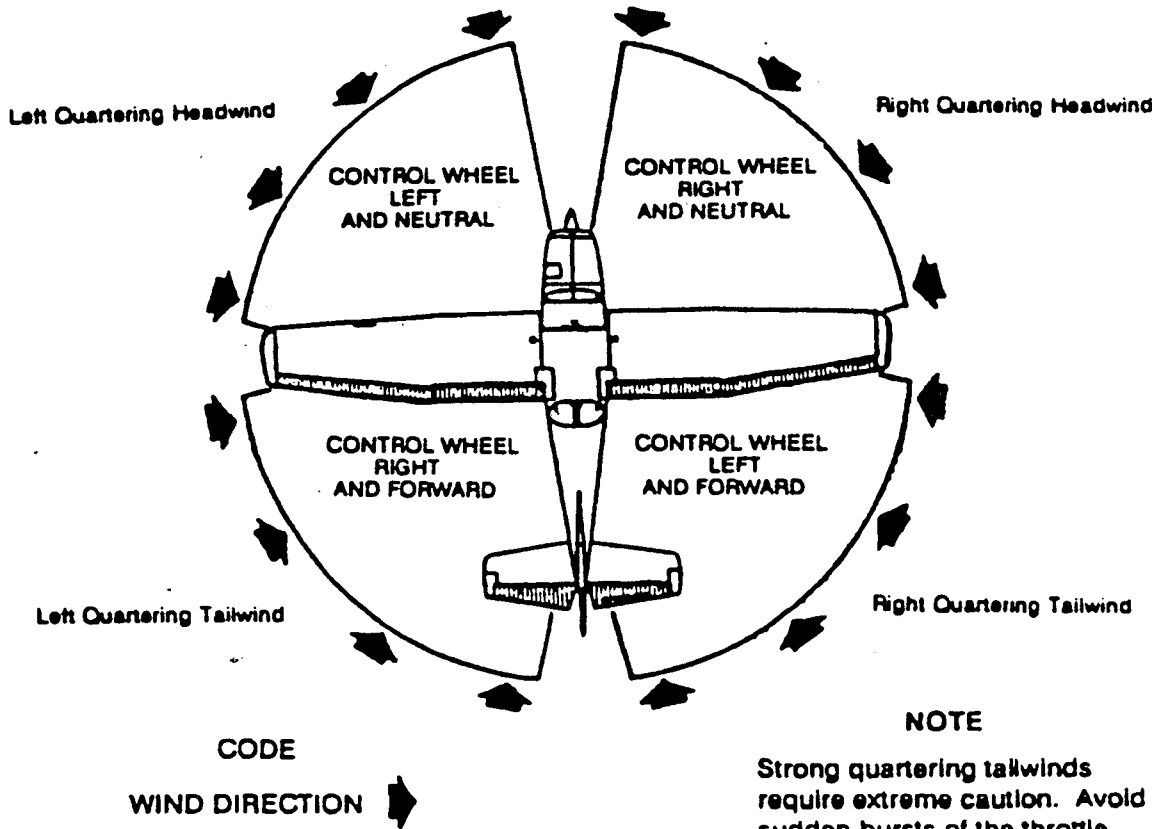

**NOTE**

Strong quartering tailwinds require extreme caution. Avoid sudden bursts of the throttle or sharp braking. Use full control deflection when positioning the control.

Figure 2-2. Wind Direction

**CAUTION**

- A large drop is not necessary. Allowing RPM to cycle to FULL DECREASE before returning the propeller control to FULL INCREASE unnecessarily places a high load on the system and can damage the governor.
- To ensure smooth oil circulation and proper operation of the governor, cycle the propeller three times during cold weather operations or if propeller response appears to be sluggish.

5. Throttle - 1000 RPM.

**NOTE**

**D** Do not retard throttle until RPM has returned to 1800 with the propeller control set at FULL INCREASE.

6. VHF Radio - SET.
7. TRANSPONDER - AS REQUIRED.
8. TRIM - SET for takeoff.
9. Doors and Windows - CLOSE and LOCK.
10. Lights and Pitot Heat - AS REQUIRED.
  - a. Strobe Light - ON.

**CAUTION**

Do not use the strobe lights until just prior to takeoff if an excessive delay is expected.

**TAKEOFF**

Refer to Appendix I for the takeoff chart showing distances required at varying gross weights, temperatures, field elevations, winds, and runway conditions.

**WARNING**

**D** Abort the takeoff if RPM does not indicate 2650 minimum or stabilizes above 2800.

Maintain directional control by use of nosewheel steering. Hold the elevator slightly aft of neutral to keep weight off the nose gear and hold aileron into the wind.

At 50 to 60 mph, raise the nose smoothly to takeoff altitude. Maintain this attitude and allow the aircraft to fly off the ground, which will normally occur between 70 and 80 mph.

**WARNING**

- Avoid wake turbulence. The T-41 is particularly susceptible to wake turbulence because of its short wingspan and light gross weight. The vortex-produced rolling movement can exceed the aileron authority of the aircraft. Allow a minimum of two minutes before ~~takeoff~~ behind a heavier aircraft or helicopter. This time should be extended behind heavy and jumbo category aircraft. With a crosswind of over 5 knots, the spacing requirement may be reduced, but attempt to remain upwind of the preceding aircraft's flightpath.
- **D** At low pressure altitude manifold pressure may exceed 25 inches during full throttle operations. Do not reduce throttle (manifold pressure) until called for in the After Takeoff Checklist.

**CAUTION**

To prevent RPM from momentarily surging beyond 2800, apply throttle smoothly and slowly. Momentarily stopping at half throttle and then continuing to full throttle will help ensure smooth acceleration and governor operation.

**NOTE**

- If a significant crosswind exists delay rotation to takeoff attitude until 70 mph.
- Apply full throttle for all takeoffs and check engine instruments early on takeoff roll.

## Short Field Takeoff

For obstacle clearance, perform the takeoff with 10-degree flaps at the best angle-of-climb speed (70-mph). If no obstructions are ahead, a best flaps-up rate-of-climb speed (95 mph) will be more efficient. The use of 10-degree flaps will shorten the ground run approximately 10 percent and will shorten the total distance to clear a 50-foot obstacle by approximately 5 percent. Once safely airborne, clear of obstacles, and at a minimum of 85 mph, raise the flaps.

## Soft Field Takeoff

Soft field takeoffs are performed with 10-degree flaps by lifting the nosewheel off the ground as soon as practical and leaving the ground in a slightly higher than normal attitude. However, the aircraft should be leveled off immediately to accelerate to a safe climb speed. Once safely airborne and at a minimum of 85 mph, raise the flaps.

## AFTER TAKEOFF

1. Engine Instruments- CHECK.
2. Flaps - UP.
3. **D** Throttle - 25" Manifold Pressure MAXIMUM.
4. **D** Propeller - 2600 RPM.

### NOTE

Rotate the propeller control knob slowly counter-clockwise until RPM reduces to 2600. Use of the propeller control lock button for this operation may result in erratic control of RPM.

## CLIMBS

Normal climbs are accomplished with full power and at a constant airspeed of 95 mph.

### CAUTION

When initiating a climb from level flight, control the rate of power increase to avoid overspeeding the engine.

## LEVEL OFF

1. Fuel Quantity - CHECK.  
Check total and balance.
2. Engine Instruments - CHECK.
3. **D** Throttle - SET FOR CRUISE.

### WARNING

Do not allow manifold pressure (throttle setting) to exceed RPM as this can cause severe engine damage.

4. **D** Propeller - SET FOR CRUISE.

### CAUTION

Do not cruise above 2600 RPM as this will result in premature wear of the engine and governor.

5. **D** Mixture - SET FOR CRUISE.

Using the cruise performance chart for the appropriate altitude, select the desired MANIFOLD PRESSURE, RPM, and lean the mixture to the specified fuel flow by rotating the mixture control knob counter-clockwise. When selecting cruise power, consider the following:

- The higher the manifold pressure and RPM, the faster the cruise speed and the higher the fuel flow.
- The lower the RPM, the quieter the engine noise.

### WARNING

Failure to lean the mixture to the specified fuel flow may result in very high fuel consumption rates, particularly at low pressure altitudes. This situation could result in fuel exhaustion in less than 3.5 hours of flight.

**CAUTION**

Monitor cylinder head temperature and engine operation after leaning the mixture. While the normal operating range for the cylinder head temperature is the green arc, it is unusual for it to indicate higher than the "H" in "Head" on the gauge. If the cylinder temperature indicates higher than usual or the engine seems to be running roughly, enrich the mixture as necessary.

**NOTE**

Be aware that the Cylinder Head Temperature gauge indicates number 3 cylinder head temperature only. High temperatures in the other cylinders may be indicated by engine roughness or an oil temperature rise.

6. TRANSPONDER - CHECK ALT.

7. NAV - AS REQUIRED

(Navigation sorties only). To perform the check, proceed as follows:

- a. Tune and identify the station.
- b. Center the course deviation indicator needle with a TO indication.
- c. Check that the course under the upper vertical index, if flown, would take the aircraft to the VOR station.

**BEFORE DESCENT**

Before making a descent from cruise altitude, proceed as follows:

1. Fuel Quantity - CHECK.

Check total and balance.

2. **D** Mixture - RICH.

**WARNING**

Descending to low altitude without enriching the mixture may cause engine

damage or possible fuel starvation and engine failure.

3. ~~Flight Instruments - AS REQUIRED.~~

- a. Crosscheck the heading indicator with the magnetic compass and reset if necessary.
- b. Check that the proper altimeter setting is being used.

**WARNING**

**D** Do not allow manifold pressure to exceed RPM as this can cause severe engine damage. Reduce throttle (manifold pressure) as necessary to adjust speed during the descent.

**APPROACH TO FIELD**

Before entering the traffic pattern, complete the following:

1. Altimeter - SET to local barometric pressure.
2. TRANSPONDER - AS REQUIRED.

**BEFORE LANDING**

The following steps will be accomplished before each landing:

1. Landing/Taxi Light - AS REQUIRED.
2. Flaps - AS REQUIRED.

(On base or final).

**WARNING**

Because of wake turbulence, allow a minimum of 2 minutes before landing behind a heavier aircraft or helicopter. This time should be extended behind heavy and jumbo category aircraft. With a crosswind component of over 5 knots, the spacing requirement may be reduced, but attempt to remain above and upwind of the preceding aircraft's flightpath.

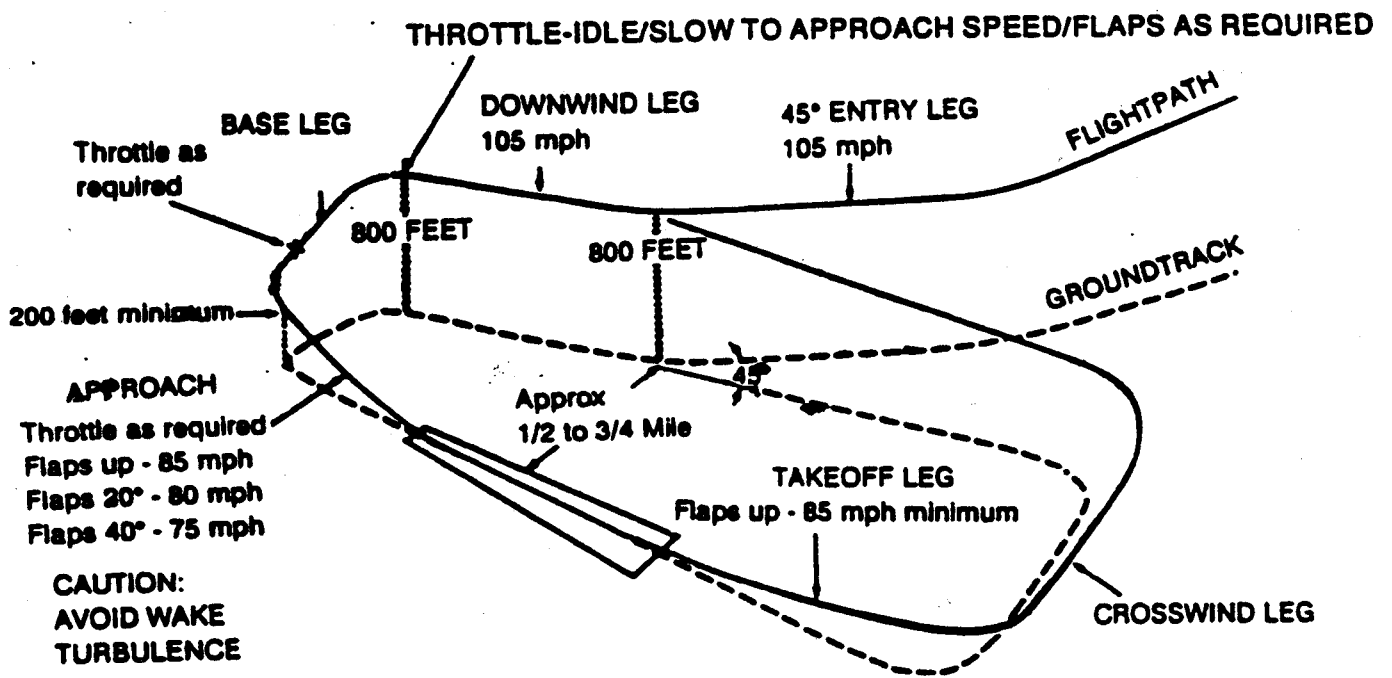

Throttle - Idle/slow to approach speed/Flaps as required.

Figure 2-3. Traffic Pattern

### 3. **D** Propeller - FULL INCREASE.

#### **CAUTION**

Advance the propeller to FULL INCREASE after power has been reduced to descend to base leg. Placing the propeller control to FULL INCREASE at high power unnecessarily places a high load on the system and will result in premature wear of the engine and governor.

### **D** Throttle Application

Applying throttle when transitioning from a low to a high power setting (as during takeoff, touch-and-go landings, level off from a glide, or go-arounds) must be done smoothly to avoid placing undue stress on the governor.

#### **CAUTION**

If done properly, RPM will never increase beyond 2800. If RPM momentarily surges beyond 2800, this may indicate that throttle application has been too abrupt.

## LANDING

### Normal Landing

The normal landing is accomplished from a rectangular pattern. Downwind should be 3/4 of a mile from the runway and flown at 800 feet AGL and 105 mph. Reduce power to idle on downwind abeam the 1/2 mile point on final and slow to approach speed in level flight. Normal configuration is 20 degrees of flaps, lowered (below 100 mph) on downwind. Turn base leg immediately after establishing the 80 mph approach speed. Maintain 80 mph throughout base and final. Power should be added at any time that it is required to maintain a normal glidepath for the flap setting. Under most conditions, this is a power-on approach.

#### **WARNING**

Retracting the flaps on final approach combined with low airspeed may cause the aircraft to stall.

During the final approach, adjust the aimpoint to arrive over the runway threshold at an altitude and airspeed which may permit a smooth reduction in power and gradual increase in pitch attitude for touchdown on the main wheels. Attempting to touchdown at an excessive airspeed may result in a three-point or nosewheel first landing, which may cause porpoising or wheelbarrowing. After touchdown, continue to hold sufficient back pressure to keep the nosewheel off the runway. Maintain directional control using nosewheel steering and differential braking as necessary.

As forward airspeed decreases, control effectiveness is reduced. Therefore, it may be necessary to increase aileron and rudder inputs to keep the aircraft on centerline and prevent landing in a crab. Upon rollout from a full stop, use nosewheel steering to keep the aircraft on centerline and aileron into the wind to keep the upwind wing down.

### No-Flap Landing

Traffic pattern procedures are similar to the normal landing except that flaps are not used. Approach speed is 85 mph. If wind conditions (i.e., tailwinds) result in a need to slip, during subsequent no-flap patterns reduce bank angle during turn from downwind to base to allow for a longer final.

### Full Flap Landing

The full flap landing permits a slightly steeper final approach and a slower approach speed. The full flap pattern should be flown as the normal pattern except that downwind is displaced 1/2 mile from the runway. Power is reduced to idle abeam the 1/4 mile point on final, and flaps are lowered to full on final. Maintain 80 mph while the flaps are at 20 degrees and 75 mph once flaps are lowered to full. Additional spacing must be obtained on takeoff leg when planning a full flap landing.

#### **WARNING**

Do not slip when using over 30 degrees of flaps due to a possible downward pitch under certain combinations of airspeed and sideslip angles.

## Crosswind Landing

Use the wing-low method, crab, or a combination of both to maintain runway alignment on final approach.

Touchdown using the wing-low method. Use aileron throughout the landing roll to counteract the effect of the crosswind. After touchdown, lower the nose smoothly to the runway as soon as possible and maintain directional control by using nosewheel steering. To preclude wheelbarrowing, avoid using excessive forward control wheel pressures at high speeds. In strong or gusty crosswinds, fly a no-flap approach and add 5 to 10 mph to the no-flap approach speed.

## Straight-In Approach

If it is necessary to land from a straight-in approach, the aircraft should normally be positioned for at least a 2-mile final. Flap setting, appropriate final approach airspeed, and interception of an extended glidepath should be attained prior to 3/4 of a mile from the runway.

### CAUTION

If a hard landing occurs, full stop the aircraft. Contact maintenance for a landing gear/tire check prior to takeoff, if possible.

## Short Field Landing

For a short field landing, fly a full flap approach at 65 mph (utility category) or 75 mph (normal category), using enough power to clear any obstacles. Immediately after touchdown, lower the nose and apply maximum braking.

## Soft Field Landing

For landing on a soft or unprepared surface, fly a full flap approach as for a short field landing. Plan to touchdown with the minimum descent rate practical. After touchdown, hold the nosewheel off the ground as long as possible.

## Braking Procedure

Braking effectiveness increases as forward speed decreases. Use the brakes as necessary to decel-

erate the aircraft to a safe taxi speed before turning off the runway.

### NOTE

Holding the control wheel aft of neutral will decrease aircraft weight on the nosewheel and increase braking effectiveness.

If maximum braking is required, lower the nosewheel to the runway, raise the flaps (if used), and apply the brakes, constantly increasing pedal pressure as the aircraft's speed decreases.

### CAUTION

Applying heavy braking immediately after touchdown may result in a skid and possible blown tire.

## Landing On Slippery Runways

Aerobrake as long as possible by maintaining the landing attitude with back pressure until the nosewheel can no longer be kept off the runway. Then use nosewheel steering for directional control. Continue to hold full nose-up elevator, retract the flaps, and use brakes lightly. If brakes are applied suddenly, or too hard, a skid may result. If skidding occurs, reduce or release pressure on both brakes, use nosewheel steering to regain directional control, and cautiously reapply the brakes.

## GO-AROUND

If conditions make a landing or approach unsafe, make a go-around. Make the decision to go around as soon as possible. If touchdown is unavoidable, do not try to hold the aircraft off the runway, but continue to fly the aircraft to touchdown. If a touchdown is made, lower the nose slightly to a normal takeoff attitude and allow the aircraft to accelerate to takeoff.

When a go-around is required at low altitude, proceed as follows:

1. Throttle - FULL IN.
2. Flaps - UP.

Raise the flaps to 20 degrees as soon as conditions permit. Raise the flaps to 0 degrees after attaining a minimum of 85 mph.

**WARNING**

Avoid using excessive bank angles at low altitudes because stall speed increases as bank angle increases and sufficient attitude may not be available for recovery.

**TOUCH-AND-GO PROCEDURES**

1. Establish takeoff attitude and apply full power.

**NOTE**

The nosewheel should normally not be lowered to the runway during normal or no-flap touch-and-go landings.

**WARNING**

If a full flap landing was accomplished, raise the flaps to approximately 20 degrees prior to applying power for the touch-and-go.

**NOTE**

Engine instruments should be checked as soon as practical after applying full power to confirm that the engine is operating normally.

2. When safely airborne and at a minimum of 85 mph, raise the flaps.

**AFTER LANDING**

After completing the landing roll and clearing the runway, proceed as follows:

1. VHF Radio - SET.
2. Lights/Pitot Heat - AS REQUIRED.
  - a. Landing/Taxi Light - OFF.
  - b. Pitot Heat - OFF.
  - c. Strobe Lights - OFF.

3. Flaps - UP.
4. VOR - OFF.
5. Transponder - OFF.

**ENGINE SHUTDOWN**

1. Parking Brake - SET.
2. Radio - OFF.
3. Throttle - IDLE (Check IDLE RPM).

**NOTE**

If idle RPM is outside the range of 850 ± 25, enter as a discrepancy in the AFTO Form 781, noting idle RPM.

4. Magneto Grounding- CHECK. (Ensure the engine will run on each magneto and will quit when the ignition switch is momentarily turned to OFF.)
5. Throttle - 1,000 to 1,200 RPM.
6. Mixture - FULL LEAN.

**CAUTION**

Run the engine at least five minutes prior to shutdown to reduce condensation in the crankcase.

7. Propeller - CHECK STOPPED.
8. Ignition Switch - OFF.

**WARNING**

Turning the ignition switch past the OFF detent may result in an ungrounded magneto.

9. Navigation Lights - OFF.
10. Master Switch - OFF.
11. Flight Instruments - CAGE (if applicable).
12. Control Lock - INSTALL.



**CAUTION**

Ensure proper positioning of control wheel prior to installing the control lock. On 1969 models, remove the control lock prior to installation of gust locks.

13. Cabin Vents, Air and Heat Knobs - CLOSE.

14. Trim - SET to TAKEOFF.

**BEFORE LEAVING AIRCRAFT**

1. AFTO Form 781 - COMPLETE.

2. Seat Belts - FASTEN.

3. Headsets - PLACE ON SEATS.

4. Chocks - INSTALL.

5. Tiedowns, Grounding Wire, Pitot Tube Cover - INSTALL.

6. Gust Locks - AS REQUIRED. Gust locks are normally not required unless strong, gusty winds are anticipated.

7. Doors and Window - CLOSE AND LOCK.

## SECTION III

## EMERGENCY PROCEDURES

## Table of Contents

INTRODUCTION .....	3-1
Critical Action Procedures .....	3-1
Noncritical Action Procedures .....	3-1
GROUND OPERATION EMERGENCIES .....	3-2
Emergency Engine Shutdown on the Ground .....	3-2
Emergency Ground Egress .....	3-2
Departing a Prepared Surface .....	3-2
TAKEOFF EMERGENCIES .....	3-2
Abort .....	3-2
Engine Failure Immediately After Takeoff .....	3-2
IN-FLIGHT EMERGENCIES .....	3-3
Engine Restart During Flight .....	3-3
Partial Engine Failure During Flight .....	3-4
Engine Fire During Flight .....	3-5
Electrical Fire .....	3-6
Smoke and Fume Elimination .....	3-6
Forced Landing .....	3-6
High Ammeter Reading .....	3-8
Negative Ammeter Reading .....	3-8
Oil System Malfunction .....	3-8
<b>D</b> Runaway Propeller .....	3-9
Structural Damage or Controllability Check .....	3-9
Asymmetrical Flaps .....	3-10
Throttle Linkage Failure .....	3-10
Pitot Static Malfunction .....	3-10
LANDING EMERGENCIES .....	3-10
Landing With a Flat Tire .....	3-10
Brake Failure .....	3-10

## INTRODUCTION

This section contains the recommended procedures for various emergency conditions. No attempt has been made to cover every conceivable malfunction or emergency. A sound knowledge of these procedures and the basic aircraft systems will, however, provide the necessary background to evaluate and cope with most emergencies. The procedures presented in **BOLD FACE TYPE** are considered critical action.

## CRITICAL ACTION PROCEDURES

Those actions which must be performed immediately if the emergency is not to be aggravated,

and injury or damage is to be avoided. These critical steps will be committed to memory.

## NONCRITICAL ACTION PROCEDURES

Those actions which contribute to an orderly sequence of events ensure that all supporting preparations are made after initiating the critical emergency actions, improve the chances for the emergency actions to be successful, and serve as cleanup items.

To assist the pilot when an emergency occurs, three basic rules are established which apply to all emergencies:

1. Maintain aircraft control.

2. Analyze the situation and take proper action.
3. Land as soon as conditions permit.

During an emergency, contact the controlling agency for assistance as soon as practical. Do not hesitate to declare an emergency. Crewmembers should take whatever action is required to safely recover the aircraft. Turn the transponder to the emergency code 7700 if warranted. Other aircraft: stay clear of the aircraft in distress and maintain radio silence; do not attempt to land at the scene of the accident; chase aircraft fly no closer than 500 feet from the disabled aircraft.

## GROUND OPERATION EMERGENCIES

### Emergency Engine Shutdown on the Ground

If an immediate engine shutdown becomes necessary while on the ground, proceed as follows:

1. MIXTURE - FULL LEAN.
2. FUEL SHUTOFF KNOB - PULL OUT.
3. IGNITION SWITCH - OFF.
4. MASTER SWITCH - OFF.

### Emergency Ground Egress

During most ground emergencies, you will normally want to egress the aircraft as soon as conditions permit. Perform the Emergency Engine Shutdown on the Ground procedures. Rapid egress is best accomplished by following an orderly sequence: Set the parking brake, remove the headset, disconnect the seat belt and shoulder harnesses, slide the seat full aft, and open the door. If the door(s) cannot be opened, kick out the window screen, side window, or baggage door. Varying circumstances will dictate how many of the above actions can be accomplished before leaving the aircraft.

### WARNING

While abandoning the aircraft, use caution for other aircraft, spinning propellers, and any other obstructions.

## NOTE

Since the right seat can be slid further aft than the left seat, exit from the aircraft may be easier through the right door.

### Departing a Prepared Surface

Any time the aircraft departs the prepared surface, accomplish immediate engine shutdown by pulling the mixture to full lean (to minimize damage to the engine should the propeller strike the ground). Maintain back pressure on the yoke to maximize the distance between the propeller and the ground. After the aircraft stops, complete the Emergency Engine Shutdown on the Ground procedures and egress the aircraft.

## TAKEOFF EMERGENCIES

### Abort

If an abort is necessary for any reason, accomplish the following:

1. THROTTLE - IDLE.
2. BRAKES - AS REQUIRED.

### CAUTION

Avoid heavy braking at high speeds as a skid and (or) blown tire is possible.

If running off the runway is imminent, shut down the engine using the mixture control.

Unless the condition causing the abort requires stopping the aircraft immediately, use as much of the remaining runway as needed to safely bring the aircraft to a stop or to slow the aircraft sufficiently to turn off the runway.

### Engine Failure Immediately After Take-off

If the engine should fail immediately after becoming airborne and altitude precludes the possibility of aborting on the runway or restarting the engine, land straight ahead, turning only as necessary to avoid obstructions. Apply the following procedures as time and conditions permit:

1. GLIDE - ESTABLISH.

- a. Flaps UP - 85 mph.
- b. Up to 20 degrees flaps - 80 mph.
- c. Over 20 degrees flaps - 75 mph.

**NOTE**

- The proper glide speed provides the optimum glide distance. See figure 3-1 for glide distances.
  - **D** If oil pressure is available the propeller pitch may still be controllable. In such an event, moving the propeller control knob to FULL DECREASE will provide the optimum glide distance.
2. MIXTURE - FULL LEAN.
  3. FUEL SHUTOFF KNOB - PULL OUT.
  4. IGNITION SWITCH - OFF.
  5. FLAPS - AS REQUIRED.
  6. MASTER SWITCH - OFF.

**WARNING**

- Do not attempt to turn back to the runway, or spend excessive time trying to accomplish the checklist. A stall or loss of aircraft control may result.
- If time permits, each crewmember should ensure that seat belts are tightened and shoulder harnesses are locked. The cabin doors should be unlocked open, especially if landing in rough terrain.

**IN-FLIGHT EMERGENCIES****Engine Restart During Flight**

An engine failure may or may not give you prior warning. Prior warning is normally in the form of a rough running engine, loss of oil pressure, sudden or uncontrollable rise in oil temperature, sudden rise in oil pressure, or fluctuating RPM.

**WARNING**

If complete engine failure is accompanied by fuel fumes in the cockpit, a restart should

~~not be attempted due to the possibility of fire.~~

**NOTE**

If engine internal damage is suspected, do not attempt a restart. Accomplish forced landing procedures. However, if the engine fails for no apparent reason and time and conditions permit, a restart should be attempted.

If a restart is warranted:

1. Glide - ESTABLISH.
  - a. Flaps Up - 85 mph.
  - b. Up to 20 degrees flaps - 80 mph.
  - c. Over 20 degrees flaps - 75 mph.

**NOTE**

**D** Moving the propeller control knob to FULL DECREASE will provide the optimum glide distance.

2. Mixture - RICH.
3. Throttle - IN HALFWAY.
4. Fuel Selector - BOTH.
5. Fuel Shutoff Knob - IN.
6. Ignition Switch - BOTH.
7. Master Switch - ON.
8. Aux Fuel Pump Switch - LOW.

**NOTE**

- Engine failure may occur because of a faulty engine-driven fuel pump. Selecting LOW on the auxiliary fuel pump, accompanied with manual leaning, should alleviate the malfunction.
- Engine failure may also occur due to a clog in one of the fuel lines. Selecting HIGH on the auxiliary fuel pump may provide enough pressure to remove the clog. However, in most cases, the engine won't run continuously in the HIGH position because this can flood out the engine.

9. Ignition Switch - ~~START~~; if the propeller is stopped or is rotating intermittently.
10. **D** Propeller - AS REQUIRED.
11. Mixture - Adjust to maintain smooth engine operation.
12. If restart is unsuccessful - Refer to Forced Landing.

**WARNING**

If the engine does not start, do not waste time in futile attempts to restart the engine. Maintain the glide and make a forced landing.

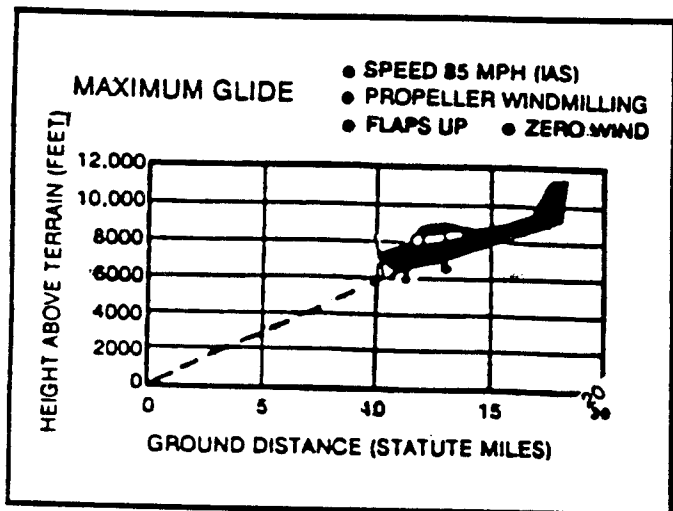

Figure 3-1. Maximum Glide

**Partial Engine Failure During Flight**

Partial engine failure may occur for several reasons, including such malfunctions as an erratic engine-driven fuel pump, a fuel leak, abnormal combustion, faulty timing, or improper positioning of a switch or

knob. Several indications usually accompany a partial power loss: fluctuating RPM, possible high oil temperature or a rough, vibrating engine. A check of the engine instruments may provide you with valuable information for regaining power. If level flight cannot be maintained, proper glide speeds will provide optimum glide performance under partial power. Apply the following procedures if a partial engine failure is suspected:

**D** Partial engine failure may occur in the T-41D for similar reasons as the T-41C. In addition, the governor may fail in the high pitch (low RPM) mode. Although very rare, this situation could result in a significant loss of thrust. Use power as required to maintain flight and proceed as follows for any partial loss of engine power:

1. Mixture - Rich.
2. **D** Propeller - FULL INCREASE.
3. Fuel Selector - BOTH.
4. Fuel Shutoff Knob - IN.
5. Manual Primer - IN AND LOCKED.

**CAUTION**

Failure to ensure manual primer is in and locked could result in fuel enrichment and a rougher running engine.

6. Master Switch - ON.
7. Ignition Switch - AS REQUIRED.

**NOTE**

- If the fuel flow indicated normal, the problem may be abnormal combustion or faulty timing.
- The engine may perform better with the ignition switch in either the LEFT or RIGHT position rather than BOTH.
- 8. Auxiliary Fuel Pump Switch - AS REQUIRED.

**WARNING**

The power loss may be the result of a fuel leak in the fuel injection system or fuel flow indicating system. With raw fuel spraying on the engine block, cooling airflow over the engine will probably prevent the fuel from igniting. Using the auxiliary fuel pump will also probably improve the engine performance. However, as the throttle is reduced during landing, the cooling airflow may not be sufficient to prevent an engine fire. Therefore, in the event of a partial power failure during flight accompanied by fuel fumes in the cockpit, fly to the nearest suitable field. Make a forced landing, shutting down the engine prior to touchdown.

**NOTE**

Partial engine failure may be caused by a malfunctioning engine-driven fuel pump. The indication will be either a drop in fuel flow or fluctuating fuel flow. The auxiliary fuel pump switch should be placed to LOW. If the LOW position does not improve engine operation, hold the switch to the HIGH position. Use the auxiliary fuel pump in the position where best performance is obtained.

9. **D** Propeller - AS REQUIRED. Cycle through full range of travel and adjust for maximum RPM if power loss is a result of governor failure.

**WARNING**

If the loss of power is a result of governor failure and control of the propeller is regained, proceed to the nearest suitable airfield and land as soon as conditions permit. Limiting maneuvering to that required for the approach will minimize possibility of another failure.

10. Mixture - Adjust to maintain smooth engine operation.

**WARNING**

If unable to maintain level flight, make a forced landing using partial power as necessary to ensure a safe approach and increased glide distance.

**CAUTION**

If a partial engine failure is encountered that allows level flight to be maintained, fly to the nearest suitable field and land. Extended flight under this condition may result in engine damage.

**Engine Fire During Flight**

Apply the following procedures in the event of an engine fire during flight:

1. MIXTURE - FULL LEAN.
2. FUEL SHUTOFF KNOB - PULL OUT.
3. IGNITION SWITCH - OFF.

**WARNING**

Do not attempt to restart an engine that has been shut down due to an engine fire. Pick a suitable field and continue with a forced landing.

4. GLIDE - ESTABLISH.
  - a. Flaps UP - 85 mph.
  - b. Up to 20 degrees flaps - 80 mph.
  - c. Over 20 degrees of flaps - 75 mph.

**D** NOTE

Moving the propeller control knob to FULL DECREASE will provide the optimum glide distance.

5. FLAPS - AS REQUIRED.
6. MASTER SWITCH - OFF.

## Electrical Fire

If an electrical fire is detected by the presence of fumes or smoke, proceed as follows:

1. MASTER SWITCH - OFF.

### WARNING

If turning off the master switch eliminates the fire situation, leave the master switch off. Do not attempt to isolate the source of the fire by checking each individual electrical component with the master switch on.

### NOTE

Circuit breakers protect most of the aircraft electrical systems and will automatically isolate the system if a short circuit occurs within the system.

## Smoke and Fume Elimination

Accomplish this procedure any time smoke or toxic odors are detected in the cabin.

1. Cabin Heat Knob - In.
2. Cabin Air Knob - In.
3. Upper Air Vents - Open.
4. Pilot's Window - As Required. If necessary, the window may be opened to assist in clearing the smoke or fumes from the cabin.

### WARNING

- Any time a crewmember or passenger experiences dizziness or a sudden headache, immediately accomplish this procedure.
- If any occupant of the aircraft is suspected of suffering physical impairment, a landing will be accomplished at the nearest suitable airport where medical assistance can be obtained.

## Forced Landing

In the event of an engine failure, and airtarts are unsuccessful or not deemed advisable, proceed as follows: (See figure 3-2, Typical Forced Landing Pattern)

1. GLIDE - ESTABLISH.
  - a. Flaps UP - 85 mph.
  - b. Up to 20 degrees flaps - 80 mph.
  - c. Over 20 degrees flaps - 75 mph.

### WARNING

A suitable field should be picked as early as possible so that maximum time will be available to plan and execute the forced landing.

### NOTE

- Proper glide speed provides the optimum glide distance.
  - **D** Glide distance with the propeller windmilling at FULL INCREASE will be significantly less than the T-41C. If oil pressure is available the propeller may still be controllable. In such an event, moving the propeller control to FULL DECREASE will provide the optimum glide distance.
2. MIXTURE - FULL LEAN.
  3. FUEL SHUTOFF KNOB - PULL OUT.
  4. IGNITION SWITCH - OFF.
  5. FLAPS - AS REQUIRED.

### NOTE

Maximum glide distance is obtained with flaps up and 85 mph. Lowering flaps will increase the angle and rate of descent.

6. MASTER SWITCH - OFF.

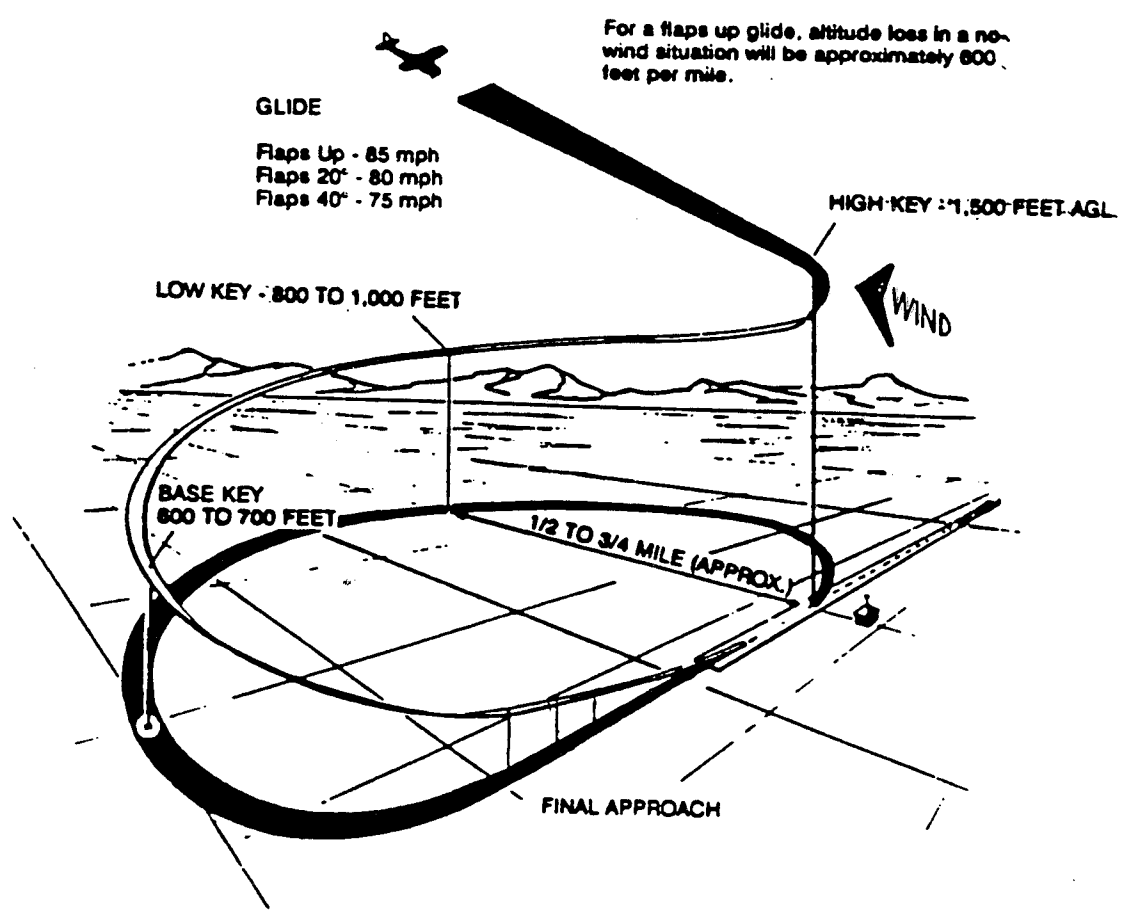

Figure 3-2. Typical Forced Landing Pattern



**WARNING**

At time permits, each crewmember should ensure that seat belts are tightened and shoulder harnesses locked. The cabin doors should be locked open, especially if landing in rough terrain.

**NOTE**

- For forced landings on unprepared surfaces, if possible, use full flaps and a 75 mph glide. Land on the main gear, holding the nosewheel off the ground as long as possible.
- Full flap glides are very steep, and require an aggressive flare just prior to touchdown in order to prevent a nosewheel first landing. Control wheel forces will be heavier than normal and up to full aft control will be required.

**High Ammeter Reading**

A high ammeter reading normally results from a malfunction in battery, regulator or alternator circuitry. If the ammeter indicates full scale rate of charge or the positive deflection is more than 2 needle widths, apply the following procedure:

1. MASTER SWITCH - OFF.

**WARNING**

Continued operation of the battery, regulator or alternator circuitry with a high ammeter reading may cause the battery to burn, boil over or explode.

**CAUTION**

If ammeter deflection follows throttle movement, a faulty regulator is usually the cause. Aircraft should be aborted if deflection is out of normal operating range.

**NOTE**

Turning the master switch off removes all electrical power to aircraft components. If electrical power is essential, the circuit malfunction may be isolated (only in 1969 model aircraft) by using only the battery side of the split master switch. If only the battery side is on, a negative ammeter will result.

**Negative Ammeter Reading**

1. Electrical Load - Reduce.

If the ammeter is showing a discharge, the alternator is not producing enough electrical power and the battery is supplying current to the electrical systems. If this occurs, turn off all lights, the pitot heat, VOR, and transponder. The Comm radio uses very little power when receiving and may be left on. Do not turn off the Master Switch. If the battery voltage is too low, you will not be able to reactivate the battery contactor relay to supply further electrical power. Plan for the possibility of complete electrical failure.

**NOTE**

If practical, make a short radio call to advise the controlling agency of your situation and intentions.

**Oil System Malfunction**

Any type of oil system malfunction is serious since it may result in engine failure. In the event of an oil system malfunction, apply the following procedures and land as soon as conditions permit:

1. Throttle - As Required. If possible, adjust the throttle to maintain the oil pressure within normal limits.

**NOTE**

**D** With total loss of oil pressure the propeller will go to low pitch (high RPM) and will not be controllable by the propeller control knob.

2. Mixture - Rich. A rich running engine runs cooler than a lean running engine.

**WARNING**

- A zero indication on the tachometer accompanied by zero oil pressure indicates an oil pump shaft shear.
- Zero oil pressure and rising oil temperature indicate the oil system has failed and engine failure is imminent - approximately 4 to 6 minutes after oil system failure.

A leaking propeller seal may greatly restrict forward visibility because of the oil on the windscreen and require a slip on final to ensure adequate visibility. A leaking propeller seal will result in depletion of the oil supply, but will probably permit enough time (approximately 15 minutes) to fly to the nearest suitable field and land.

**CAUTION**

Do not operate the engine on the ground with the oil pressure above 100 psi or below 10 psi as engine damage may result.

**NOTE**

Oil pressure relief valve failure - valve open, oil pressure will be zero; valve closed, pressure will follow throttle movements and may read higher than normal.

**D RUNAWAY PROPELLER****WARNING**

Prompt corrective action is essential to prevent engine failure due to excessive RPM.

If a failure of the governor occurs and the propeller goes into low pitch (high RPM) resulting in a runaway propeller, proceed as follows:

1. Throttle - REDUCE to maintain RPM within limits.
2. Airspeed - REDUCE

**NOTE**

Placing the aircraft into a climb to decrease airspeed will increase the load on the propeller and may help reduce RPM.

3. Propeller - CYCLE through full range of travel.

**NOTE**

If, after cycling the propeller control through the full range of travel, control is not regained, continue with this checklist and land as soon as conditions permit. If control is regained, carefully monitor RPM and terminate the mission.

4. Propeller - FULL INCREASE if control not regained.
5. Throttle - Adjust to maintain RPM within limits.

**Structural Damage or Controllability Check****CAUTION**

Do not reset the flaps if significant structural damage is located in the wings.

1. Climb to at least 1,500 feet above the terrain (if practical) at a controllable airspeed.
2. Simulate a landing approach and determine the airspeed at which the aircraft becomes difficult to control (minimum controllable airspeed).

**WARNING**

Do not allow the aircraft to stall. If the aircraft becomes difficult to control or approaches a stall, lower the nose and increase power to recover. Rudder will assist the ailerons to counter roll.

3. Plan to fly a straight-in approach. Fly the normal approach airspeed for your flap.

setting, or 5 to 10 mph above minimum controllable airspeed, whichever is higher. For asymmetrical flaps, use your minimum flap setting for approach airspeed.

4. Plan to touch down at no less than minimum controllable airspeed. Do not begin to reduce final approach airspeed until the aircraft is very close to the runway.

### Asymmetrical Flaps

If an asymmetrical flap condition occurs, use aileron and rudder as necessary to maintain aircraft control. Do not attempt to correct the situation by reversing the flaps. Do a controllability check and land as soon as conditions permit.



Further movement of the flaps may cause flap buckling and aileron damage.

### Throttle Linkage Failure

If the throttle linkage fails in-flight, the engine may remain at that power setting. Use power available and flaps as required to safely land the aircraft. If the engine is running near full power, initiate a climb in order to lower flaps below 100 mph. Flaps (full down) may be required to prevent engine overspeed. If it fails near idle, and straight and level flight cannot be maintained, use no flaps and fly at 85 mph and set up for a forced landing.

#### NOTE

- If may be possible to add additional power by pushing in the throttle, but you will not be able to pull the throttle back.
- If you must shut the engine down to land. Do so by pulling the mixture full lean. If power is needed again, mixture rich should start the engine quickly.
- The throttle may fail at any position. Use judgment to determine the best course of action.

### Pitot Static Malfunction

If the airspeed indicator is unreliable, fly known power setting and pitch pictures. Fly a pattern, maintaining 2400 RPM on downwind, 1500 RPM on base of final. Reduce the power to idle in the

roundout. Do not exceed 20° of bank, and if a stall warning indication occurs prior to the roundout, go around.

1. If icing is suspected, turn on pitot heat.

#### NOTE

If icing is suspected, use of the pitot heat may fix the problem given enough time.

2. If the airspeed indicator proves unreliable, notify RSU/SOF.
3. Fly a wider than normal pattern maintaining 2400 RPM on downwind, maintain 1500 RPM on base and final. Close the throttle in roundout.
4. Do not exceed 20 degrees of bank.
5. If you receive a stall warning indication prior to roundout, go-around.

## LANDING EMERGENCIES

### Landing With a Flat Tire

If a flat tire or tread separation occurs during takeoff and conditions do not permit an abort, land as soon as conditions permit.

If a main tire is flat, land on the side of the runway corresponding to the good tire. Maintain directional control with differential braking and nosewheel steering. If the nose tire is flat, land in the center of the runway and hold the nosewheel off the ground as long as possible. Stop the aircraft and accomplish a normal engine shutdown.

1. Main Gear: Land on the side of the runway corresponding to the good tire.
2. Nose Gear: Land in the center of the runway, hold nosewheel off the ground as long as possible.
3. Stop the aircraft on the runway. Shut aircraft down and call maintenance.

### Brake Failure

If an inoperative brake is suspected, land on the side of the runway corresponding to the inoperative brake. Use a combination of nosewheel steering and the good brake to maintain directional control. If both brakes are inoperative, land in the center of the runway. Shut down the engine and use nosewheel steering to avoid any obstacles.

**SECTION IV**

**CREW DUTIES**

---

**CREW DUTIES**

Crew duties are not applicable in this aircraft.

**SECTION V**

**OPERATING LIMITATIONS**

**Table of Contents**

Operating Limitations .....	5-1
Minimum Crew Requirements .....	5-1
Instrument Markings .....	5-1
Prohibited Maneuvers .....	5-4
Weight Limitations .....	5-4

**OPERATING LIMITATIONS**

This section includes aircraft and engine limitations which must be observed during normal operation. These limitations are derived from extensive wind tunnel and flight testing to ensure your safety and to help obtain maximum utility of the equipment.

**MINIMUM CREW REQUIREMENTS**

The minimum crew required for this aircraft is one pilot. When the aircraft is flown solo by a student pilot, the student must occupy the left seat.

■ The minimum crew required for this aircraft is one fully qualified T-41D pilot. When occupied by two squadron pilots, both must be qualified in the T-41D. Only designated IPs may qualify another pilot.

**INSTRUMENT MARKINGS**

**Airspeed Limitations**

The following are the calibrated airspeed limits for the aircraft:

- Maximum .....182 mph ■ (glide, dive, or smooth air)
- Caution Range .....145-182 mph :
- Normal Operating Range .....64-145 ■
- Flaps (maximum) .....100 mph □ (Top of the White Arc)
- Maneuvering speed .....127 mph\*

\*The maximum speed at which you can use abrupt control travel without exceeding the design load limit.

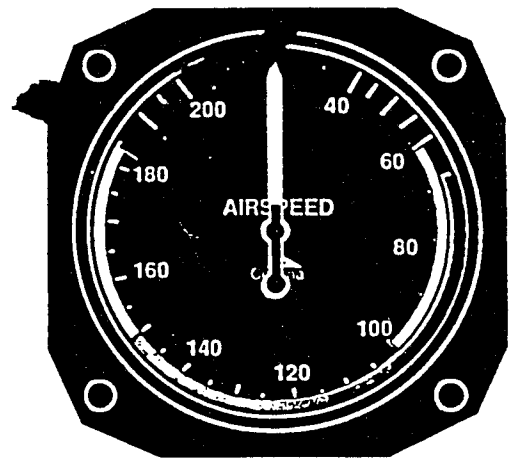

Figure 5-1. Airspeed Limitations Gauge

■ **Cylinder Head Temperature Gauge**

Normal Operating Range ..(Green Arc) ■

Maximum Allowable .....460°F ■

**Oil Temperature Gauge**

Normal Operating Range ..... ■

Maximum Allowable .....(240°) ■

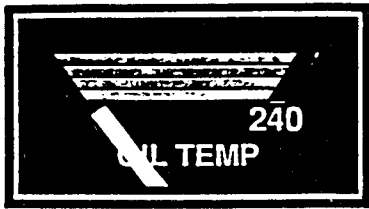

Figure 5-2. Oil Temperature Gauge

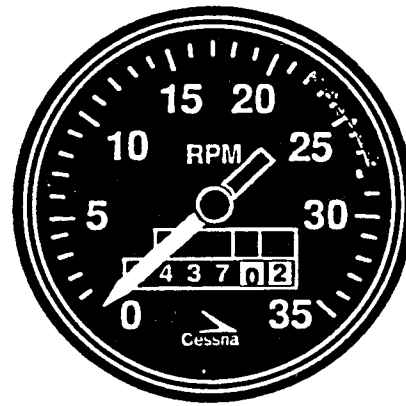

Figure 5-4. Tachometer

**Oil Pressure Gauge**

- Minimum Idling .....10 psi
- Normal Operating Range ....30-75 psi\*
- Maximum .....100 psi

\*Green Arc may indicate 30-60 psi.

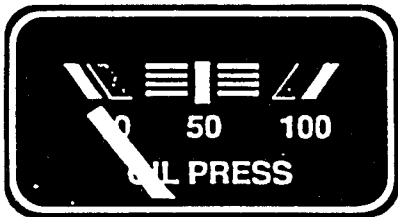

Figure 5-3. Oil Pressure Gauge

**Tachometer**

Normal operating Range:

- At Sea Level .....2200-2650 RPM  
 (Inner Green Arc)
- At 3,000 feet MSL .....2200-2725 RPM  
 (Middle Green Arc)
- At 6,000 feet MSL .....2200-2800 RPM  
 (Outer Green Arc)
- Maximum .....2800 RPM (  )  
 (engine rated speed)
- Minimum for Takeoff .....2270 RPM
- Idle RPM .....850 ± 25

**NOTE**

If RPM exceeds 2800, adjust throttle to maintain 2800 RPM or less. Make an entry in the AFTO 781 indicating highest RPM and duration (in seconds).

**D Manifold Pressure Gauge**

Normal Operating Range .....15" - 25" Hg  
 (Green Arc)

**WARNING**

Except during full throttle/prop FULL INCREASE operations such as takeoffs and go-arounds, never allow manifold pressure to exceed engine RPM.

**WARNING**

At low pressure altitudes manifold pressure may exceed 25" during takeoffs or go-arounds. Do not reduce throttle (manifold pressure) until called for in the After Takeoff checklist.

**D Propeller**

- Normal Operating Range .....2200-2600 RPM
- Maximum Allowable .....2800 RPM
- Minimum for Takeoff .....2650 RPM

**WARNING**

If RPM stabilizes above 2800 RPM refer to checklist for Runaway Propeller and terminate the mission.

**CAUTION**

Do not cruise above 2600 RPM as this will result in premature wear of the engine and governor.

**NOTE**

If RPM momentarily surges beyond 2800 when applying throttle, then stabilizes below 2800, this may indicate abrupt throttle application.

**Fuel Flow Indicator**

Normal Operating Range .....4.5-11.5 gph  
 Minimum .....  
 Maximum .....

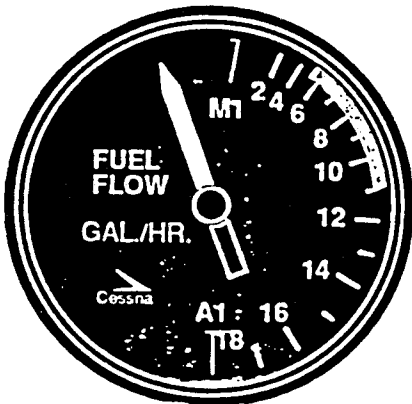

Figure 5-5. Fuel Flow Indicator

**Fuel Quantity Indicators**

Full Mark .....52 gal  
 (26 gal each tank)

Usable Fuel .....51 gal  
 (25.5 gal each tank)  
 (level flight)

Usable Fuel .....46 gal  
 (23 gal each tank)  
 (all flight conditions)

Empty .....E  
 (3 gal unusable, each tank)

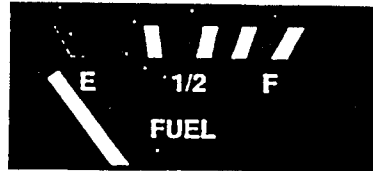

Figure 5-6. Fuel Quantity Indicator

**Suction Gauge**

At 1800 RPM or Above .....4.6-5.4  
 inches Hg

**CAUTION**

If the suction gauge reads less than 4.6 inches Hg with 1800 RPM or above, the attitude and heading indicators should be caged (1968 models). If the gauge reads less than 1 inch, the mission should be terminated.

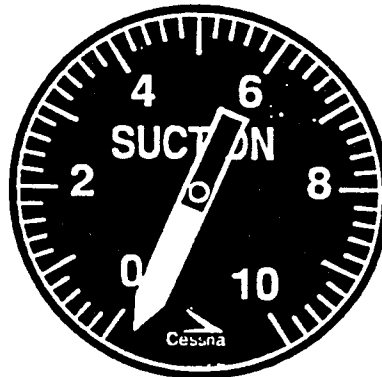

Figure 5-7. Suction Gauge

**Ammeter**

Normal 0 to +2 needle widths

Maximum (for flight) +2 needle widths

**Landing/Taxi Lights**

On Ground: Taxi Light 15 minutes  
Landing Light 5 minutes

**PROHIBITED MANEUVERS**

- \* 1. Spins.
- 2. Whip stalls.
- 3. IMC flight
- \* 4. Formation flight.
- 5. Touchdowns from SFLs (except on prepared surfaces at authorized airfields).
- \* 6. Night flight.
- 7. Aerobatic maneuvers.
- 8. Maneuvers requiring zero or negative G flight.
- 9. Engine shutdowns in-flight for practice.
- 10. Slips with over 30° flaps extended.

\* See Cessna Model R172E Flight handbook  
Spins - Slow Deceleration on entry

**WEIGHT LIMITATIONS**

**Normal Category (Gross Weight - 2,500 lbs)**

This aircraft is certified in both the normal and utility category. The normal category is applicable to aircraft intended for nonaerobatic operations, these include any maneuvers incidental to normal flying, stalls (except whip stalls), and turns in which the angle of bank is not more than 60 degrees.

**D Weight Limitations**

Normal Category - Gross Weight .....2,550 lbs

Utility Category - Gross Weight .....2,250 lbs

**Utility Category (Gross Weight - 2,200 lbs)**

This aircraft is not designed for purely aerobatic flight. However, certain maneuvers are allowed when the aircraft is operated in the utility category. In the utility category, the area behind the pilot's and instructor's seats must not be occupied.

For center of gravity and weight and balance computations, refer to the Appendix.

*Air Form 487*



# SECTION VI

# FLIGHT CHARACTERISTICS

## Table of Contents

General Flight Characteristics .....	6-1
Stalls .....	6-1
Spins .....	6-1
Flight Controls .....	6-2
Takeoff Run .....	6-2
Climb Performance .....	6-2
Cruise Performance .....	6-2
Idle Descent .....	6-2

## GENERAL FLIGHT CHARACTERISTICS

Control forces are light. Adequate stability and control are available throughout the operating speed range. When properly trimmed, in the clean configuration, the aircraft will remain in straight-and-level flight with little attention from the pilot.

**D** The pilot may notice the T-41D has a heavier nose during rotation for takeoff and in the flare. It is more difficult to hold the nosewheel off the runway during a touch-and-go.

## STALLS

The stall characteristics of the aircraft are conventional in all configurations. Stall warning is provided by a stall-warning horn between 5 and 10 mph above the stall, and in some instances, by a noticeable aircraft buffeting. In a power-on situation the aircraft may or may not buffet prior to stalling. If recovery is not initiated at this point, the nose will fall abruptly even if full aft elevator is held. One wing may drop before the other if the aircraft is in uncoordinated flight when it stalls. The factors that affect the stalling characteristics are: weight, load factor, airspeed, flap setting, power setting, and coordination (slips or skids). Refer to figures 6-1 and 6-2 for stall speeds.

When the aircraft approaches a stall, the control surfaces lose some, if not all, of their effectiveness. As the angle of attack increases, the order in which the loss of control surface effectiveness occurs is: ailerons, elevator, and rudder. During the recovery from a stall, the control surfaces will regain their effectiveness in the reverse order. The aircraft is constructed so that the wing will stall progressively outward from the wing root to the wingtip. This is called "washout" and provides aileron control effectiveness as long as possible.

POWER OFF 2200 POUNDS GROSS WEIGHT	STALLING SPEEDS			
	MPH, CAS			
	Angle of Bank			
Condition	0°	20°	40°	60°
Flaps Up	60	61	68	80
Flaps 20°	55	57	63	78
Flaps 40°	49	51	56	70

Figure 6-1

POWER OFF 2500 POUNDS GROSS WEIGHT	STALLING SPEEDS			
	MPH, CAS			
	Angle of Bank			
Condition	0°	20°	40°	60°
Flaps Up	64	66	73	90
Flaps 20°	58	60	67	83
Flaps 40°	53	55	60	75

Figure 6-2

**D** The stall characteristics of the aircraft are conventional in all configurations and are identical to the T-41C.

## SPINS

The T-41 is inherently resistant to spins; however, an inadvertent spin may occur if the aircraft is mishandled during a stall or stall recovery. Normally neutralizing all controls will recover the aircraft.

If the aircraft continues to spin, use the following recovery technique:

1. Check the throttle in idle and the ailerons are neutral.

2. Apply and hold full rudder opposite to the direction of rotation.

**NOTE**

If disorientation precludes a visual determination of the direction of rotation, refer to the turn needle. The needle deflects in the direction of rotation.

3. After the rudder reaches the stop, briskly move the control wheel far enough forward to break the stall.

**NOTE**

Full down elevator may be required at aft center of gravity loadings to ensure optimum recovery.

4. Hold these controls until rotation stops.



Premature relaxation of the control inputs may delay the recovery, resulting in additional altitude loss.

5. As the rotation stops, neutralize the rudder and make a smooth recovery from the resulting dive.

Application of this recovery technique will produce prompt recoveries (within 1/4 turn).

**FLIGHT CONTROLS**

Elevator control forces are relatively light in cruising flight at all aircraft weights and CGs.

Aileron control forces are light. The ailerons are effective at all speeds up to the actual stall. Rudder forces are comparatively light and only slight rudder pressure is required when rolling into and out of turns.

Elevator trim is effective throughout most of the speed range of the aircraft. At very low airspeeds, sufficient trim may not be available to relieve all control pressures.

**TAKEOFF RUN**

**D** The T-41D accelerates faster and becomes airborne in less distance than the T-41C. At sea level this amounts to a 16% shorter take-off roll

while at 10,000 feet it would result in a 6% reduction. Refer to the appendix for specific climb performance.

**CLIMB PERFORMANCE**

The best rate-of-climb airspeed has been determined to vary with altitude. At sea level, the best rate-of-climb airspeed is 100 mph, while at 10,000 feet MSL the airspeed is 91 mph. (These airspeeds apply at 2500 lbs gross weight. Refer to Appendix for airspeeds at lighter weights.) The best angle-of-climb can be achieved with either a clean configuration and 85 mph, or 10 degrees of flaps and 70 mph. (The latter configuration and airspeed is the recommended procedure for obstacle-clearance takeoffs.)

These airspeeds apply at 2500 lbs gross weight. Refer to Appendix for airspeeds at other weights

**D** Climb performance for any given set of conditions is improved over the T-41C. The pilot can expect an average of 6% higher rate of climb in the T-41D. Refer to the appendix for specific climb performance.

**CRUISE PERFORMANCE**

**D** The T-41D generally cruises faster than the T-41C, particularly at low pressure altitudes. It is also slightly more fuel efficient at high altitude, but not significantly so. Refer to the cruise performance charts in the appendix for specific information.



Failure to lean the mixture to the appropriate fuel flow setting as specified in the appropriate cruise performance chart may result in very high fuel consumption and exhaustion in less than 3.5 hours of flight.

**IDLE DESCENT**

Due to a significant increase in parasite drag during idle operations with the propeller at FULL INCREASE low blade angle (such as the descent from downwind to touchdown in the pattern), the T-41D can develop a very high sink at approach speeds. This makes it possible to fly a much tighter pattern at idle. For the same reason, the T-41D will decelerate much faster than the T-41C.

**SECTION VII**

**ALL-WEATHER OPERATION**

**Table of Contents**

Introduction .....	7-1
Instrument Flight .....	7-1
Ice and Rain .....	7-1
Turbulence and Thunderstorms .....	7-1
Night Flying .....	7-2
Cold Weather Operations .....	7-2
Hot Weather Operations .....	7-2

**INTRODUCTION**

This section discusses special all-weather procedures and techniques which either emphasize or add to procedures and techniques presented in Sections II and III.

effectiveness is reduced. Use caution as the possibility of hydroplaning exists on a wet runway.

**WARNING**

**INSTRUMENT FLIGHT**

IMC flight in the T-41C is prohibited.

Crosswinds present more directional control difficulty on a wet runway than on a dry runway. Maintain proper crosswind control inputs throughout the landing roll to aid in directional control.

**ICE AND RAIN**

**Ice**

*ADDITION  
SEE  
15-2*

**WARNING**

Do not take off with any ice, snow or frost on the wings, windows or tail (including all control surfaces). Ice, snow or frost may reduce forward visibility, change the lift and stall characteristics of the aircraft, and cause possible binding of the control surfaces.

**CAUTION**

Taxiing through snow drifts or over accumulation of ice may result in propeller damage.

**Rain**

A full flap landing is recommended. Raising the flaps on landing roll will increase the aircraft weight on the main landing gear and decrease the possibility of hydroplaning. When landing on a wet runway, expect a longer landing roll as braking

**TURBULENCE AND THUNDERSTORMS**

**WARNING**

Flights through thunderstorms or areas of severe turbulence must be avoided. Particularly at low pressure altitudes, the T-41D may cruise at airspeeds well above maneuvering speed. If unexpected turbulence or vertical air currents are encountered, reduce throttle (manifold pressure) and then RPM if necessary to slow to a maximum of 127 MPH (maneuvering speed). The combination of very high airspeed and severe turbulence may result in overstressing the aircraft and possible structural failure.

Penetrating a thunderstorm is not recommended under any circumstances. Remain VFR and land at a suitable field where a safe landing can be made.

If unexpected turbulence is encountered, use smooth, positive control inputs. Extreme up and down drafts can cause large attitude, airspeed,

and altitude deviations. Do not chase airspeed or altitude; maintain aircraft attitude and attempt to exit the area of turbulence as soon as possible.

## NIGHT FLYING

- Night flying in the T-41 is prohibited.

## COLD WEATHER OPERATIONS

The T-41 engine is considered cold soaked when the ambient temperature is below 35°F and the engine has not been operated for an extended period.

### Engine Start

1. Mixture - RICH.
2. **D** PROPELLER - FULL INCREASE.
3. Throttle - IDLE.
4. Manual Primer - 2 to 6 strokes. Leave primer charged and ready for stroke.

#### NOTE

After pulling the primer out, wait a few seconds to allow sufficient fuel to enter the primer. If properly primed, some resistance will be felt when pushing the primer in.

5. Master Switch - ON.
6. Navigation Lights - ON.
7. Throttle - IN (1/4 to 1/2 inch).
8. Auxiliary Fuel Pump Switch - LOW (if required).

#### CAUTION

Limit use of the auxiliary fuel pump to prevent overpriming and flooding. Excessive cranking will rapidly drain battery power.

9. Propeller Danger Area - CLEAR.
10. Ignition Switch - START (release when engine starts).
11. Auxiliary Fuel Pump Switch - OFF and GUARDED.
12. Throttle - 1000 RPM minimum.
13. Manual Primer - IN and LOCKED.
14. Engine Instruments - CHECK.

#### NOTE

Below 0°F the oil pressure gauge should show a positive indication within 1 minute of engine start.

### Engine Warmup

If the engine is cold soaked, no indication will be apparent on the oil temperature gauge and the oil pressure gauge will read low. Engine warmup may require up to 10 minutes for the oil pressure to indicate in the normal operating range. Take-off will be delayed until normal oil pressure, 30 to 75 psi, is indicated. If no oil temperature is noted, accelerate the engine several times to higher engine RPM. If the engine accelerates smoothly and the oil pressure remains normal and steady, the aircraft is ready for takeoff.

## HOT WEATHER OPERATIONS

For hot weather operations; use normal procedures and note the following: Avoid prolonged engine operation on the ground as the heat from the engine may cause vapor lock to develop in the fuel lines. If the engine quits or will not start and vapor lock is suspected, the system may be purged by checking the mixture control knob at full lean, throttle at idle, and holding the auxiliary fuel pump switch in HIGH for 5 to 10 seconds or more to flush the vapor through the fuel lines. Turn the pump off and proceed with the normal starting procedures.

## APPENDIX

## PERFORMANCE DATA

## Table of Contents

Introduction .....	A-1
Airspeed Conversion .....	A-2
Airspeed Correction .....	A-3
Weight and Balance .....	A-4
Center of Gravity .....	A-5
Loading Chart .....	A-5
Takeoff and Landing Crosswind Chart .....	A-6
Takeoff Data .....	A-7
Rate of Climb Data .....	A-7
Optimum Cruise Performance .....	A-7
Cruise and Range Performance .....	A-8
Landing Distance Table .....	A-8
<b>D</b> Takeoff Data, T-41D Model .....	A-9
<b>D</b> Rate of Climb Data, T-41D Model .....	A-9
<b>D</b> Cruise Performance (2500 ft) .....	A-10
<b>D</b> Cruise Performance (5000 ft) .....	A-11
<b>D</b> Cruise Performance (7500 ft) .....	A-12
<b>D</b> Cruise Performance (10,000 ft) .....	A-13

## INTRODUCTION

The performance data shown on the following pages are compiled from actual tests by Cessna with the aircraft and engine in good condition and using average piloting technique and best power mixture. This data is a valuable aid for flight planning.

A power setting selected from the range chart usually will be more efficient than a random setting, since it will permit you to estimate your fuel consumption more accurately. Using the chart will pay dividends in overall efficiency.

Cruise and range performance is based on flight tests using a McCauley 1B235/DFC7850 propeller. Other conditions of the tests are shown in the chart headings. Allowance for fuel reserve, headwinds, takeoffs and climb, should be made and are in addition to those shown on the charts. Other variables such as fuel metering characteristics, engine and propeller conditions, and turbulence may account for variations of 10 percent or more in maximum range.

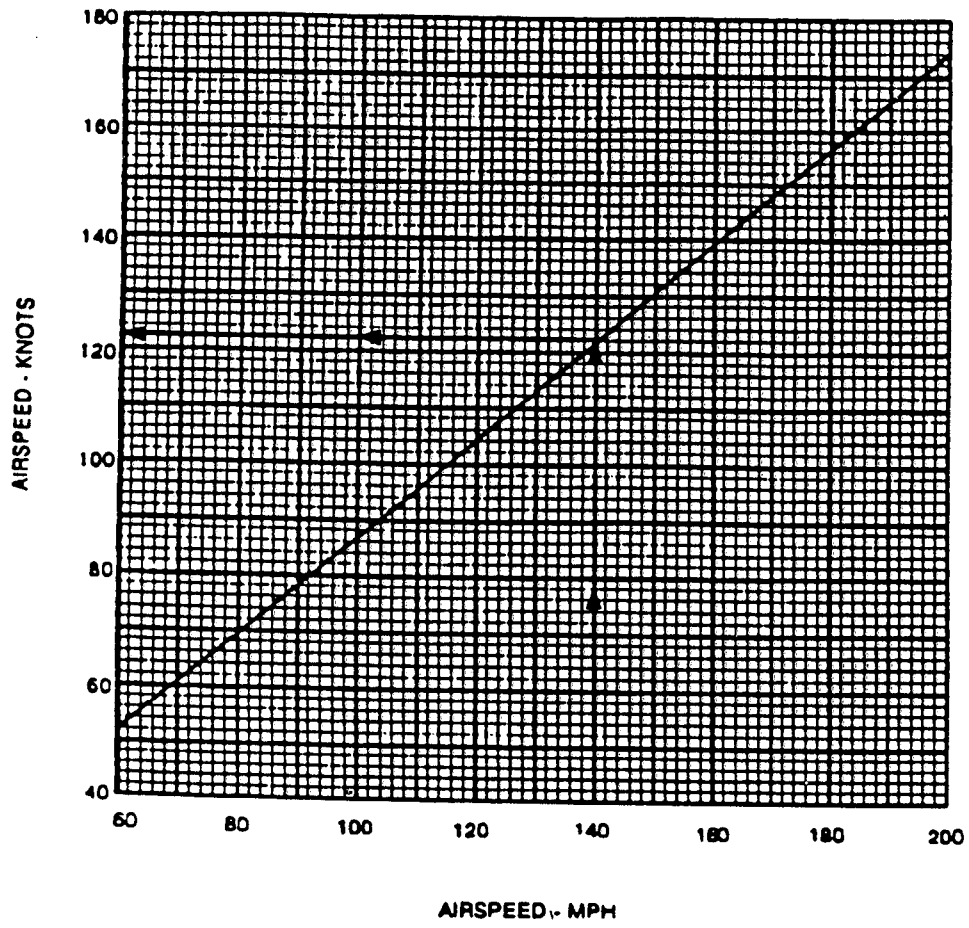

Figure A1-1. Airspeed Conversion Chart

AIRSPEED CORRECTION TABLE												
FLAPS	IAS	50	60	70	80	90	100	110	120	130	140	150
UP	CAS	60	64	69	77	86	96	106	116	126	137	147
DOWN	CAS	59	63	71	80	88	98	•	•	•	•	•

Figure A1-2. Airspeed Correction Table

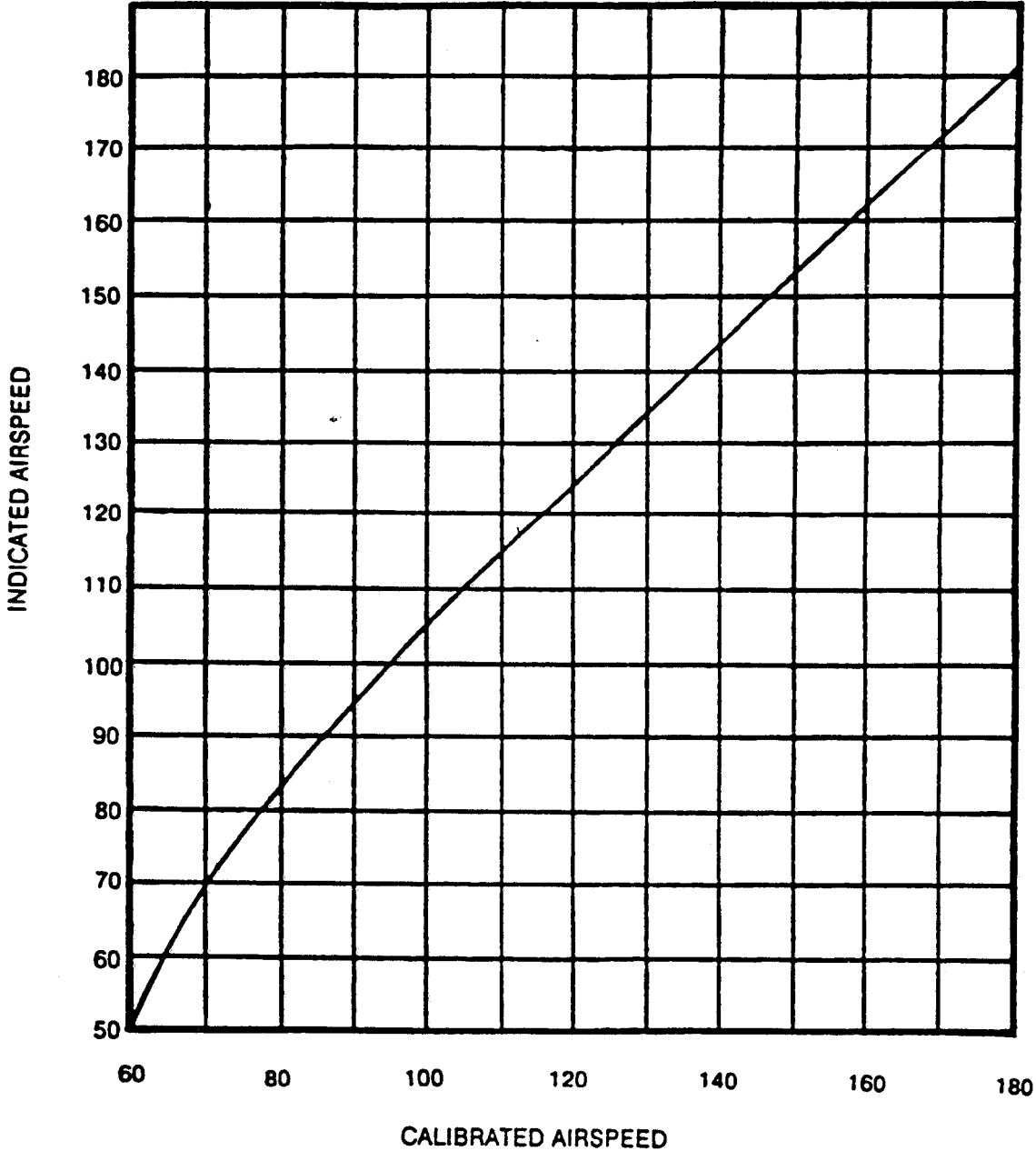

Figure A1-3. T-41C Airspeed Correction Chart

### WEIGHT AND BALANCE

The following information will enable you to operate the airplane within the prescribed weight and center of gravity limitations. To figure the weight and balance for your particular airplane, use the pertinent Sample Program, and the Loading Graph and Center of Gravity Moment Envelope as follows:

Take the licensed Empty Weight and Moment/1000 from the Weight and Balance Data sheet, plus any changes noted on forms FAA-337, carried in your airplane, and write them down in the proper columns. Using the Loading Graph, determine the moment/1000 of each item to be carried. Total the weights and moments /1000 and use the Center of Gravity Moment Envelope to determine whether the point falls within the envelope, and if the loading is acceptable.

SAMPLE LOADING PROBLEM (UTILITY CATEGORY)	SAMPLE AIRPLANE		YOUR AIRPLANE	
	Weight (lbs.)	Moment (lb.-ins. /1000)	Weight (lbs.)	Moment (lb.-ins. /1000)
1. Licensed Empty Weight (Sample Airplane) .....	1443	54.1		
2. Oil (10 pts - Full oil may be assumed for all flights) .....	19	-0.4	19	-0.4
3. Fuel (46 gal. at 6 lbs/gallon) .....	276	13.2		
4. Pilot and Instructor .....	400	14.4		
5. TOTAL WEIGHT AND MOMENT .....	2138	81.3		
6. Locate this point (2138 at 81.3) on the center of gravity moment envelope, and since this point falls within the envelope, the loading is acceptable.				

SAMPLE LOADING PROBLEM (NORMAL CATEGORY)	SAMPLE AIRPLANE		YOUR AIRPLANE	
	Weight (lbs.)	Moment (lb.-ins. /1000)	Weight (lbs.)	Moment (lb.-ins. /1000)
1. Licensed Empty Weight (Sample Airplane) .....	1468	56.1		
2. Oil (10 pts - Full oil may be assumed for all flights) .....	19	-0.4	18	-0.4
3. Fuel (46 gal. at 6 lbs/gallon) .....	276	13.2		
4. Pilot and Front Passenger .....	400	14.4		
5. Rear Passengers (or baggage in same area) ..	200	14.0		
6. Baggage .....	120	11.4		
7. TOTAL WEIGHT AND MOMENT .....	2483	108.7		
8. Locate this point (2483 at 108.7) on the center of gravity moment envelope, and since this point falls within the envelope, the loading is acceptable.				

Figure A1-4. Weight and Balance Chart



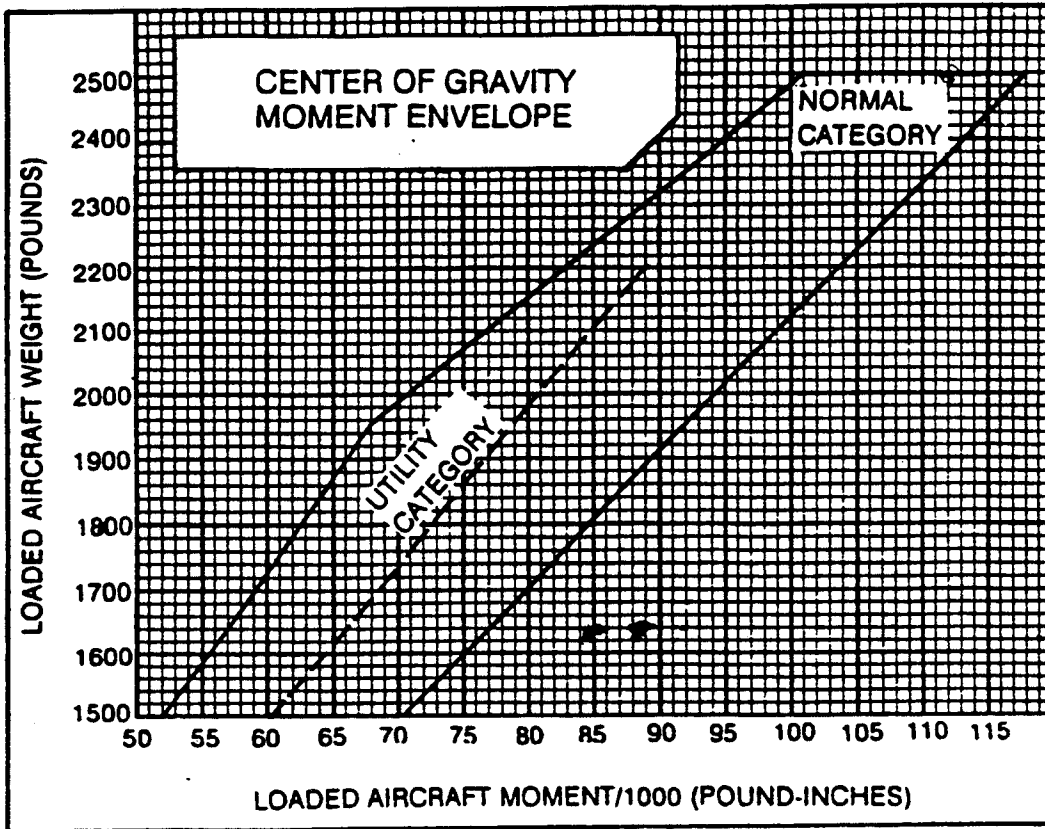

Figure A1-5. Center of Gravity Moment Envelope

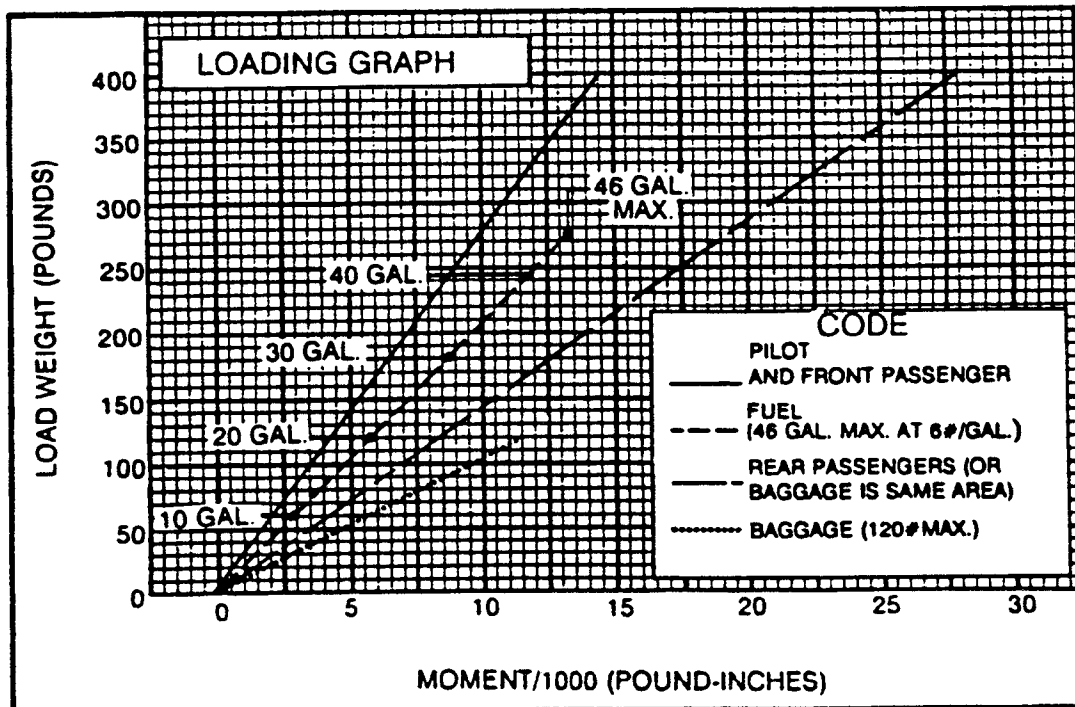
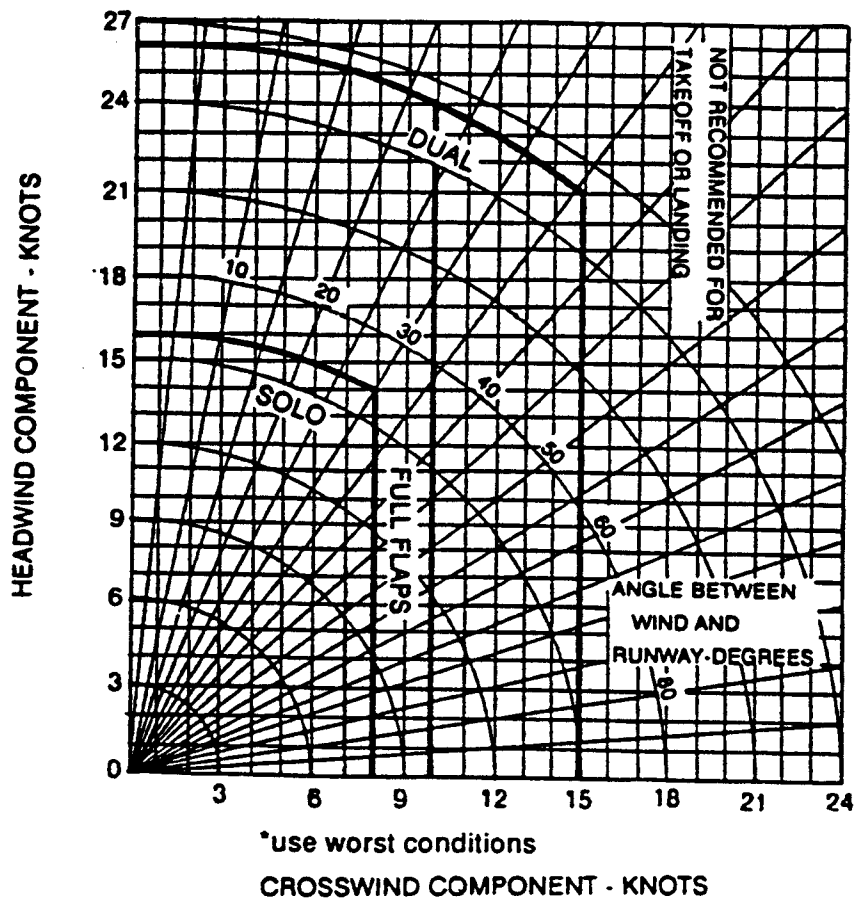

Figure A1-6. Loading Graph



**TAKEOFF AND LANDING CROSSWIND CHART**

**WIND LIMITATIONS**

	Maximum Any Direction	Maximum Crosswind Components	
		(0-20° Flaps)	(Full Flaps)
DUAL	26 Knots	15 Knots	10 Knots
SOLO	16 Knots	8 Knots	

Aircraft will not be moved without wing walkers when winds (steady state or gusts) exceed 26 knots. Taxi operations will cease when winds (steady state or gusts) exceed 35 knots.

Figure A1-7. Takeoff and Landing Crosswind Chart

## T-41C AIRCRAFT

TAKE-OFF DATA HARD SURFACE RUNWAY, FLAPS 10°										
GROSS WEIGHT LBS	IAS AT 50 FT MPH	HEAD WIND KNOTS	@ S.L. & 59°F		@ 2,500 ft & 50°F		@ 5,000 ft & 41°F		@ 7,500 ft & 32°F	
			GROUND RUN	TOTAL TO CLEAR 50' OBS	GROUND RUN	TOTAL TO CLEAR 50' OBS	GROUND RUN	TOTAL TO CLEAR 50' OBS	GROUND RUN	TOTAL TO CLEAR 50' OBS
2500	70	0	860	1360	1000	1555	1135	1765	1435	2225
		10	605	1020	710	1175	820	1350	1050	1730
		20	390	720	470	840	550	980	730	1270
2200	66	0	645	1055	750	1200	845	1340	1070	1670
		10	440	780	520	890	595	1005	785	1265
		20	275	535	330	620	385	715	570	910
1900	61	0	470	805	540	905	610	1000	770	1230
		10	310	580	365	860	415	740	535	915
		20	180	390	220	445	260	510	340	640

NOTES: 1. Increase distance 10% for each 25°F above standard temperature for particular altitude.  
2. For operation on a dry, grass runway, increase distance (both "ground run" and "total to clear 50 ft obstacle") by 7% of the "total to clear 50 ft obstacle" figure.

Figure A1-8. Take-Off Data

MAXIMUM RATE-OF-CLIMB DATA												
GROSS WEIGHT LBS	IAS MPH	@ S.L. & 59°F		@ 5,000 ft & 41°F			@ 10,000 ft & 23°F			@ 15,000 ft & 5°F		
		RATE OF CLIMB FT/MIN	GAL OF FUEL USED	IAS MPH	RATE OF CLIMB FT/MIN	FROM S.L. FUEL USED	IAS MPH	RATE OF CLIMB FT/MIN	FROM S.L. FUEL USED	IAS MPH	RATE OF CLIMB FT/MIN	FROM S.L. FUEL USED
2500	100	880	1.3	95	620	2.9	91	395	4.8	87	150	8.2
2200	97	1070	1.3	92	800	2.6	89	530	4.0	85	260	6.3
1900	94	1310	1.3	89	1000	2.3	87	695	3.5	83	390	5.1

NOTES: 1. Flaps up, full throttle, and mixture at recommended leaning schedule.  
2. Fuel used includes warm-up and take-off allowance.

Figure A1-9. Maximum Rate-of-Climb Data

OPTIMUM CRUISE PERFORMANCE			
ALTITUDE	RPM	TRUE AIRSPEED	RANGE
4500	2700	133	570
6500	2750	135	580
8500	2800	138	590

Figure A1-10. Optimum Cruise Performance

**T-41C AIRCRAFT**

<b>CRUISE &amp; RANGE PERFORMANCE</b>	Gross Weight - 2,500 Lbs Standard Conditions Zero Wind 46 Gal of Fuel (No Reserve)
---------------------------------------	---

ALT.	RPM	% BHP	TAS MPH	GAL/HOUR	ENDR. HOURS	RANGE MILES
2500	2600	67	128	10.3	4.5	575
	2500	61	123	9.3	4.9	610
	2400	55	118	8.5	5.4	640
	2300	60	111	7.7	6.0	670
	2200	44	103	6.9	6.6	680
5000	2700	70	133	10.6	4.5	575
	2600	64	128	9.7	4.7	610
	2500	58	123	8.8	5.2	640
	2400	52	116	8.0	5.7	665
	2300	47	108	7.3	6.9	685
2200	41	96	6.6	7.0	675	
7500	2800	72	138	11.0	4.2	580
	2700	66	133	10.0	4.6	610
	2600	60	128	9.2	5.0	640
	2500	54	121	8.4	5.5	670
	2400	49	113	7.6	6.1	685
2300	44	102	5.9	6.7	680	
10000	2800	68	138	10.4	4.4	615
	2700	62	133	9.5	4.8	640
	2600	57	126	8.7	5.3	670
	2500	51	118	7.8	6.3	690
	2400	46	107	7.2	6.4	690
2300	41	90	6.5	7.1	635	

Figure A1-11. Cruise & Range Performance Data

<b>LANDING DISTANCE TABLE</b> LANDING DISTANCE WITH FULL FLAPS, POWER OFF, AND NO WIND ON HARD SURFACE RUNWAY									
GROSS WEIGHT LBS	APPROACH IAS MPH	@ S.L. & 59°F		@ 2,500 ft & 50°F		@ 5,000 ft & 41°F		@ 7,500 ft & 32°F	
		GROUND RUN	TOTAL TO CLEAR 50' OBS	GROUND RUN	TOTAL TO CLEAR 50' OBS	GROUND RUN	TOTAL TO CLEAR 50' OBS	GROUND RUN	TOTAL TO CLEAR 50' OBS
2500	75	610	1320	650	1390	685	1470	725	1560

NOTES: 1. Reduce landing distance 10% for each 5 knots of headwind.  
2. For operation on a dry, grass runway, increase distance (both "ground roll" and "total to clear 50 ft. obstacle") by 20% of the "total to clear 50 ft obstacle" figure.

Figure A1-12. Landing Distance Data

## T-41D AIRCRAFT

TAKE-OFF DATA, T-41D MODEL										
TAKE-OFF DISTANCE FROM HARD SURFACE RUNWAY WITH FLAPS 10°										
GROSS WEIGHT LBS	IAS AT 50 FT MPH	HEAD WIND KNOTS	@ S.L. & 59°F		@ 2,500 ft & 50°F		@ 5,000 ft & 41°F		@ 7,500 ft & 32°F	
			GROUND RUN	TOTAL TO CLEAR 50' OBS	GROUND RUN	TOTAL TO CLEAR 50' OBS	GROUND RUN	TOTAL TO CLEAR 50' OBS	GROUND RUN	TOTAL TO CLEAR 50' OBS
2550	71	0	740	1230	880	1440	1065	1725	1290	2095
		10	520	925	630	1100	770	1330	945	1630
		20	335	660	415	795	520	975	655	1215
2200	66	0	525	920	625	1070	755	1255	910	1495
		10	360	685	435	800	530	950	650	1140
		20	225	475	275	560	345	680	430	825
1900	61	0	380	710	450	810	540	940	650	1105
		10	250	515	305	595	370	700	450	825
		20	150	350	185	410	230	485	285	585

NOTES: 1. Increase distance 10% for each 25°F above standard temperature for particular altitude.  
2. For operation on a dry, grass runway, increase distance (both "ground run" and "total to clear 50 ft obstacle") by 7% of the "total to clear 50 ft obstacle" figure.

Figure A1-13. **D** Take-Off Data, T-41D Model

MAXIMUM RATE-OF-CLIMB DATA, T-41D MODEL												
GROSS WEIGHT LBS	IAS MPH	@ S.L. & 59°F		@ 5,000 ft & 41°F			@ 10,000 ft & 23°F			@ 15,000 ft & 5°F		
		RATE OF CLIMB FT/MIN	GAL OF FUEL USED	IAS MPH	RATE OF CLIMB FT/MIN	FROM S.L. FUEL USED	IAS MPH	RATE OF CLIMB FT/MIN	FROM S.L. FUEL USED	IAS MPH	RATE OF CLIMB FT/MIN	FROM S.L. FUEL USED
2550	95	880	1.3	91	650	3.1	87	420	5.3	83	190	8.8
2200	92	1120	1.3	88	860	2.7	85	595	4.3	81	340	6.4
1900	88	1390	1.3	85	1095	2.3	82	800	3.5	79	505	5.1

NOTES: 1. Flaps up, full throttle, 2800 RPM and mixture at recommended leaning schedule.  
2. Fuel used includes warm-up and take-off allowance.  
3. For hot weather, decrease rate of climb 20 ft/min for each 10°F above standard day temperature for particular altitude.

Figure A1-14. **D** Maximum Rate-of-Climb Data, T-41D Model

**T-41D AIRCRAFT**



<b>CRUISE PERFORMANCE</b>						
<b>NORMAL LEAN MIXTURE</b>						
Standard Conditions 		Zero Wind 		Gross Weight - 2550 LBS		
2500 FEET						
RPM	MP	%BHP	TAS MPH	GAL/ HOUR	46 GAL (NO RESERVE)	
					ENDR. HOURS	RANGE MILES
2600	24	77	139	11.7	3.9	550
	23	72	135	11.0	4.2	570
	22	67	131	10.2	4.5	590
	21	62	127	9.5	4.8	610
2500	25	78	139	11.8	3.9	540
	24	73	136	11.1	4.1	565
	23	69	132	10.5	4.4	580
	22	64	128	9.8	4.7	605
2400	25	73	136	11.1	4.1	565
	24	69	132	10.5	4.4	580
	23	65	129	9.8	4.7	600
	22	60	125	9.2	5.0	620
2300	25	68	132	10.4	4.4	585
	24	64	128	9.8	4.7	600
	23	60	124	9.2	5.0	620
	22	56	120	8.6	5.3	645
2200	25	63	128	9.7	4.8	605
	24	60	124	9.1	5.0	625
	23	56	120	8.6	5.4	645
	22	52	115	8.0	5.7	660
	21	48	110	7.5	6.1	675
	20	44	105	7.0	6.6	690
	19	41	98	6.5	7.1	695
	18	37	91	6.0	7.7	695

Figure A1-15. Cruise Performance (2500 feet)

## T-41D AIRCRAFT

## CRUISE PERFORMANCE

## NORMAL LEAN MIXTURE

Standard Conditions

Zero Wind

Gross Weight - 2550 LBS

5000 FEET

RPM	MP	%BHP	TAS MPH	GAL/ HOUR	46 GAL (NO RESERVE)	
					ENDR. HOURS	RANGE MILES
2600	23	75	141	11.4	4.0	565
	22	71	137	10.7	4.3	585
	21	66	132	10.0	4.6	605
	20	61	128	9.3	4.9	630
2500	23	72	138	11.0	4.2	580
	22	68	134	10.3	4.5	600
	21	63	130	9.6	4.8	620
	20	58	125	8.9	5.2	645
2400	23	68	134	10.3	4.5	600
	22	63	130	9.7	4.8	620
	21	59	126	9.0	5.1	640
	20	55	121	8.4	5.5	660
2300	23	63	130	9.7	4.8	620
	22	59	126	9.0	5.1	640
	21	55	121	8.4	5.4	660
	20	51	116	7.9	5.8	675
2200	23	59	126	9.0	5.1	640
	22	55	121	8.5	5.4	660
	21	51	116	7.9	5.8	675
	20	47	111	7.4	6.2	690
	19	43	104	6.9	6.7	700
	18	40	97	6.4	7.2	705
	17	36	89	5.9	7.8	700

Figure A1-16. Cruise Performance (5000 feet)

T-41D AIRCRAFT



CRUISE PERFORMANCE						
NORMAL LEAN MIXTURE						
Standard Conditions 		Zero Wind 		Gross Weight - 2550 LBS		
7500 FEET						
RPM	MP	%BHP	TAS MPH	GAL/ HOUR	46 GAL (NO RESERVE)	
					ENDR. HOURS	RANGE MILES
2600	21	69	138	10.5	4.4	605
	20	64	134	9.8	4.7	625
	19	60	129	9.1	5.1	650
	18	55	123	8.4	5.5	675
2500	21	66	135	10.1	4.6	620
	20	62	131	9.4	4.9	640
	19	57	125	8.7	5.3	665
	18	52	119	8.0	5.7	685
2400	21	62	131	9.5	4.9	635
	20	58	127	8.8	5.2	660
	19	53	121	8.2	5.6	680
	18	49	115	7.6	6.0	695
2300	21	58	127	8.9	5.2	660
	20	54	122	8.3	5.6	675
	19	50	116	7.7	6.0	690
	18	45	109	7.1	6.5	700
2200	21	54	122	8.3	5.5	675
	20	50	116	7.8	5.9	690
	19	46	110	7.2	6.4	700
	18	42	103	6.7	6.9	710
	17	38	95	6.2	7.4	710

Figure A1-17. Cruise Performance (7500 feet)



## T-41D AIRCRAFT



<b>CRUISE PERFORMANCE</b>						
<b>NORMAL LEAN MIXTURE</b>						
Standard Conditions 		Zero Wind 		Gross Weight - 2550 LBS		
10,000 FEET						
RPM	MP	%BHP	TAS MPH	GAL/ HOUR	46 GAL (NO RESERVE)	
					ENDR. HOURS	RANGE MILES
2600	19	63	135	9.6	4.8	645
	18	58	129	8.9	5.2	670
	17	53	122	8.2	5.6	690
	16	48	114	7.5	6.2	705
2500	19	60	132	9.2	5.0	660
	18	55	126	8.5	5.4	680
	17	50	118	7.8	5.9	700
	16	46	110	7.1	6.4	710
2400	19	56	127	8.6	5.3	675
	18	52	121	8.0	5.7	695
	17	47	113	7.4	6.2	705
	16	43	105	6.8	6.8	715
2300	19	52	121	8.1	5.7	690
	18	48	115	7.5	6.1	705
	17	44	107	6.9	6.6	715
	16	40	99	6.4	7.2	715
2200	19	49	116	7.6	6.0	700
	18	45	109	7.1	6.5	710
	17	41	102	6.5	7.0	715
	16	37	93	6.0	7.6	715

Figure A1-18. Cruise Performance (10,000 feet)

## GLOSSARY

---

### A

AGL - Above Ground Level

### B

BHP - Brake Horse Power

### C

°C - Temperature in degrees Centigrade

CAS - Calibrated Airspeed

### D

### E

### F

°F - Temperature in degrees Fahrenheit

F/F - Fuel Flow

### G

G, g - Unit of acceleration. One g is the normal acceleration due to gravity

GA - Go-around. Mode of operation of flight

GAL/HR - Gallon of fuel used in one hour

GPH - Gallons Per Hour

### H

### I

IAS - Indicated Air Speed. Actual reading on panel instrument (airspeed indicator)

IFF - Identification Friend or Foe, interrogation communication equipment.

### J

### K

KHz - Kilohertz (Kilocycles per second)

KTS - Knots

### L

### M

MHz - Megahertz (Megacycles per second), 1000 KHz

MPH - Miles Per Hour

### N

NAVAID - Integration of communication equipment within and beyond the aircraft

### O

OBS - Omni Bearing Selector

### P

PSI - Pounds per Square Inch

### Q

### R

RPM - Revolutions Per Minute

### S

### T

TCTO - Time Compliance Technical Order

### U

### V

VHF - Very High Frequency (30 to 300 MHz)

VOR - VHF Omnidirectional Radio Range (Omnirange) (VHF navigation aid)

VVI - Vertical Velocity Indicator

### W

### X

### Y

### Z

## INDEX

## ALPHABETICAL

	Page		Page
<b>A</b>		Cylinder Head Temperature Gauge .....	5-1
Abort .....	3-2	<b>D</b>	
After Landing .....	2-14	Departing a Prepared Surface .....	3-2
After Takeoff .....	2-9	Dimensions .....	1-1
Airspeed Conversion .....	A-2	<b>E</b>	
Airspeed Correction .....	A-3	Electrical Fire .....	3-6
Airspeed Indicator .....	1-15	Electrical System .....	1-10
Airspeed Limitations .....	5-1	Emergency Engine Shutdown on the Ground ...	3-2
Altimeter .....	1-15	Emergency Ground Egress .....	3-2
Ammeter .....	1-11	Engine .....	1-1
Ammeter .....	5-4	Engine Driven Fuel Pump .....	1-10
Approach to Field .....	2-10	Engine Failure Immediately After Takeoff .....	3-2
Asymmetrical Flaps .....	3-10	Engine Fire During Flight .....	3-5
Attitude Indicator .....	1-15	Engine Instruments .....	1-6
Auxiliary Fuel Pump .....	1-10	Engine Restart During Flight .....	3-3
<b>B</b>		Engine Shutdown .....	2-14
Before Descent .....	2-10	Engine Start .....	7-2
Before Landing .....	2-10	Engine Warmup .....	7-2
Before Leaving Aircraft .....	2-15	Exterior Inspection .....	2-2
Before Starting Engine .....	2-4	External Power Receptacle .....	1-11
Before Takeoff .....	2-6	<b>F</b>	
Before Taxiing .....	2-6	Flight Control System .....	1-14
Brake Failure .....	3-10	Flight Controls .....	6-2
Brake System .....	1-13	Forced Landing .....	3-6
Braking Procedure .....	2-13	Fuel Flow Indicator .....	1-6
<b>C</b>		Fuel Flow Indicator .....	5-3
Cabin Doors .....	1-20	Fuel Injection/Air Induction System .....	1-2
Cabin Door Movable Window .....	1-20	Fuel Quantity Indicator .....	1-10
Cabin Heating and Ventilation System .....	1-19	Fuel Quantity Indicators .....	5-3
Carbon Monoxide Detector .....	1-20	Fuel System .....	1-7
Center of Gravity .....	A-5	Full Flap Landing .....	2-12
Circuit Breakers and Fuses .....	1-13	<b>G</b>	
Climb Performance .....	6-2	General Flight Characteristics .....	6-1
Climbs .....	2-9	Go-Around .....	2-13
Clock .....	1-16	Gross Weight .....	1-1
Cold Weather Operations .....	7-2	GROUND OPERATION EMERGENCIES .....	3-2
Communications/Navigation Equipment .....	1-16	<b>H</b>	
Control Lock/Gust Locks .....	1-14	Heading Indicator .....	1-16
Critical Action Procedures .....	3-1	High Ammeter Reading .....	3-8
Crosswind Landing .....	2-13	Hot Weather Operations .....	7-2
Cruise and Range Performance .....	A-8	<b>I</b>	
Cruise Performance .....	6-2	Ice and Rain .....	7-1
Cruise Performance (10,000 ft) .....	A-13	Ice .....	7-1
Cruise Performance (2500 ft) .....	A-10	Idle Descent .....	6-2
Cruise Performance (5000 ft) .....	A-11		
Cruise Performance (7500 ft) .....	A-12		
Cylinder Head Temperature .....	1-6		

	Page		Page
Ignition Switch .....	1-2	Oil System Malfunction .....	3-8
Ignition System .....	1-2	Oil system .....	1-7
IN-FLIGHT EMERGENCIES .....	3-3	Oil Temperature Gauge .....	1-6
Instrument Flight .....	7-1	Oil Temperature Gauge .....	5-1
Instrument Markings .....	5-1	Operating Limitations .....	5-1
Instruments .....	1-14	Optimum Cruise Performance .....	A-7
Interior Inspection .....	2-1	Overhead Speaker System .....	1-16
Interior Lighting .....	1-19		
Interphone System .....	1-16	<b>P</b>	
INTRODUCTION .....	3-1	Parking Brake .....	1-13
Introduction .....	2-1	Partial Engine Failure During Flight .....	3-4
Introduction .....	7-1	Pitot Heat .....	1-15
Introduction .....	A-1	Pitot Static Malfunction .....	3-10
		Pitot Static System and Instruments .....	1-14
<b>J</b>		Prohibited Maneuvers .....	5-4
<b>K</b>		Propeller .....	1-5
<b>L</b>		Propeller .....	5-2
LANDING EMERGENCIES .....	3-10	Propeller Control Knob .....	1-6
Landing .....	2-12		
Landing and Taxi Lights .....	1-19	<b>Q</b>	
Landing Distance Table .....	A-8	<b>R</b>	
Landing On Slippery Runways .....	2-13	Rain .....	7-1
Landing/Taxi Lights .....	5-4	Rate of Climb Data .....	A-7
Landing With a Flat Tire .....	3-10	Rate of Climb Data, T-41D Model .....	A-9
Level Off .....	2-9	Runaway Propeller .....	3-9
Lighting .....	1-17		
Loading Chart .....	A-5	<b>S</b>	
		Seat Belts and Shoulder Harnesses .....	1-20
<b>M</b>		Seat Operation .....	1-20
Magnetic Compass .....	1-16	Short Field Landing .....	2-13
Manifold Pressure & Engine RPM .....	1-5	Short Field Takeoff .....	2-9
Manifold Pressure Gauge .....	1-6	Smoke and Fume Elimination .....	3-6
Manifold Pressure Gauge .....	5-2	Soft Field Landing .....	2-13
Manual Primer .....	1-10	Soft Field Takeoff .....	2-9
Master Switch .....	1-11	Spins .....	6-1
Minimum Crew Requirements .....	5-1	Stall Warning Horn .....	1-14
Mixture Control .....	1-2	Stalls .....	6-1
		Starting Engine .....	2-4
<b>N</b>		Starting System .....	1-2
Navigation Lights .....	1-17	Straight-In Approach .....	2-13
Negative Ammeter Reading .....	3-8	Strobe Lights .....	1-19
Night Flying .....	7-2	Structural Damage or Controllability Check .....	3-9
No-Flap Landing .....	2-12	Suction Gauge .....	5-3
Noncritical Action Procedures .....	3-1		
Normal Category .....	5-4	<b>T</b>	
Normal Landing .....	2-12	Tachometer .....	1-6
Nosewheel Steering System .....	1-13	Tachometer .....	5-2
		TAKEOFF EMERGENCIES .....	3-2
<b>O</b>		Takeoff .....	2-8
Oil Pressure Gauge .....	1-7	Takeoff and Landing Crosswind Chart .....	A-6
Oil Pressure Gauge .....	5-2	Takeoff Data .....	A-7
		Takeoff Data, T-41D Model .....	A-9

	Page		Page
Takeoff Run .....	6-2	VOR Receiver .....	1-17
Taxiing .....	2-6	<b>W</b>	
The Aircraft .....	1-1	Weight and Balance .....	A-4
Throttle .....	1-2	Weight Limitations .....	5-4
Throttle Application .....	2-12	Weight Limitations(T-41D) .....	5-4
Throttle Linkage Failure .....	3-10	Wing Flap System .....	1-13
Touch-and-go Procedures .....	2-14	<b>X</b>	
Transponder .....	1-17	<b>Y</b>	
Trim System .....	1-14	<b>Z</b>	
Turbulence and Thunderstorms .....	7-1		
Turn-and-Slip Indicator .....	1-15		
<b>U</b>			
Utility Category .....	5-4		
<b>V</b>			
Vacuum System .....	1-15		
Vertical Velocity Indicator (VVI) .....	1-15		
VHF Radio .....	1-16		